

SYSTEM WIRING DIAGRAMS

Audi - A4

AIR CONDITIONING

www.Mitchell-Auto.ru

1996 Audi A4

SYSTEM WIRING DIAGRAMS Audi - A4

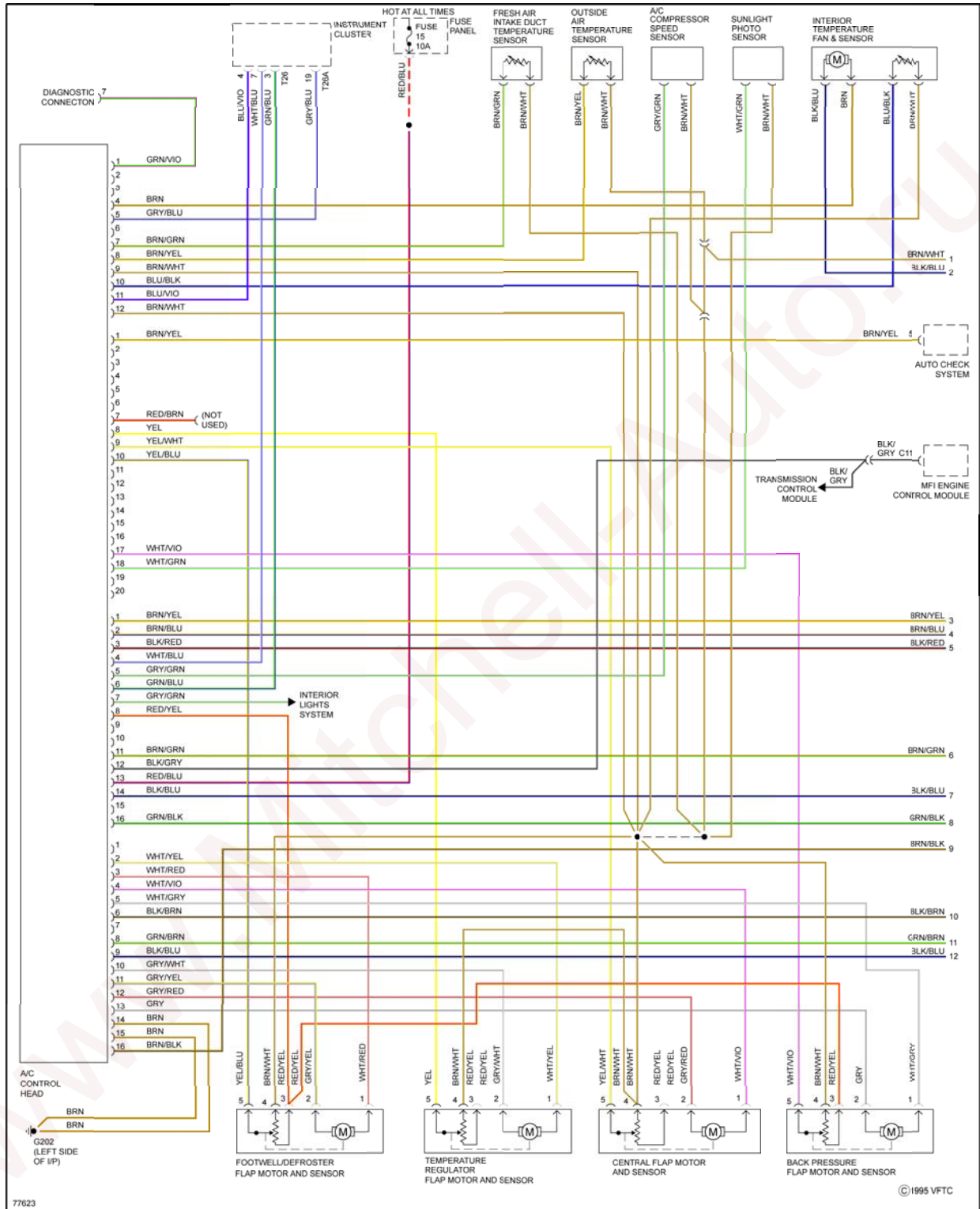

Fig. 1: Automatic A/C Circuit (1 of 2)

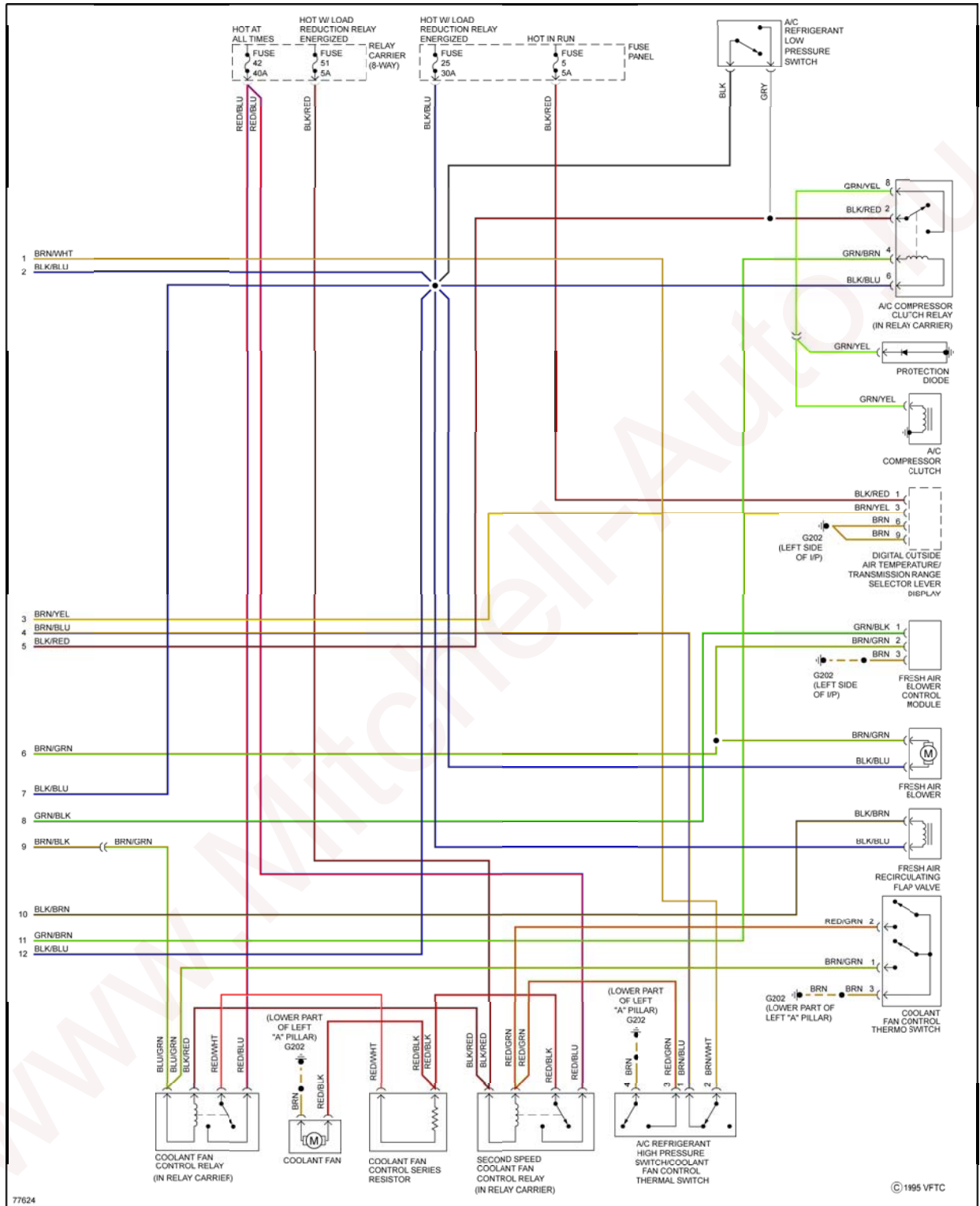

Fig. 2: Automatic A/C Circuit (2 of 2)

ANTI-LOCK BRAKES

1996 Audi A4

SYSTEM WIRING DIAGRAMS Audi - A4

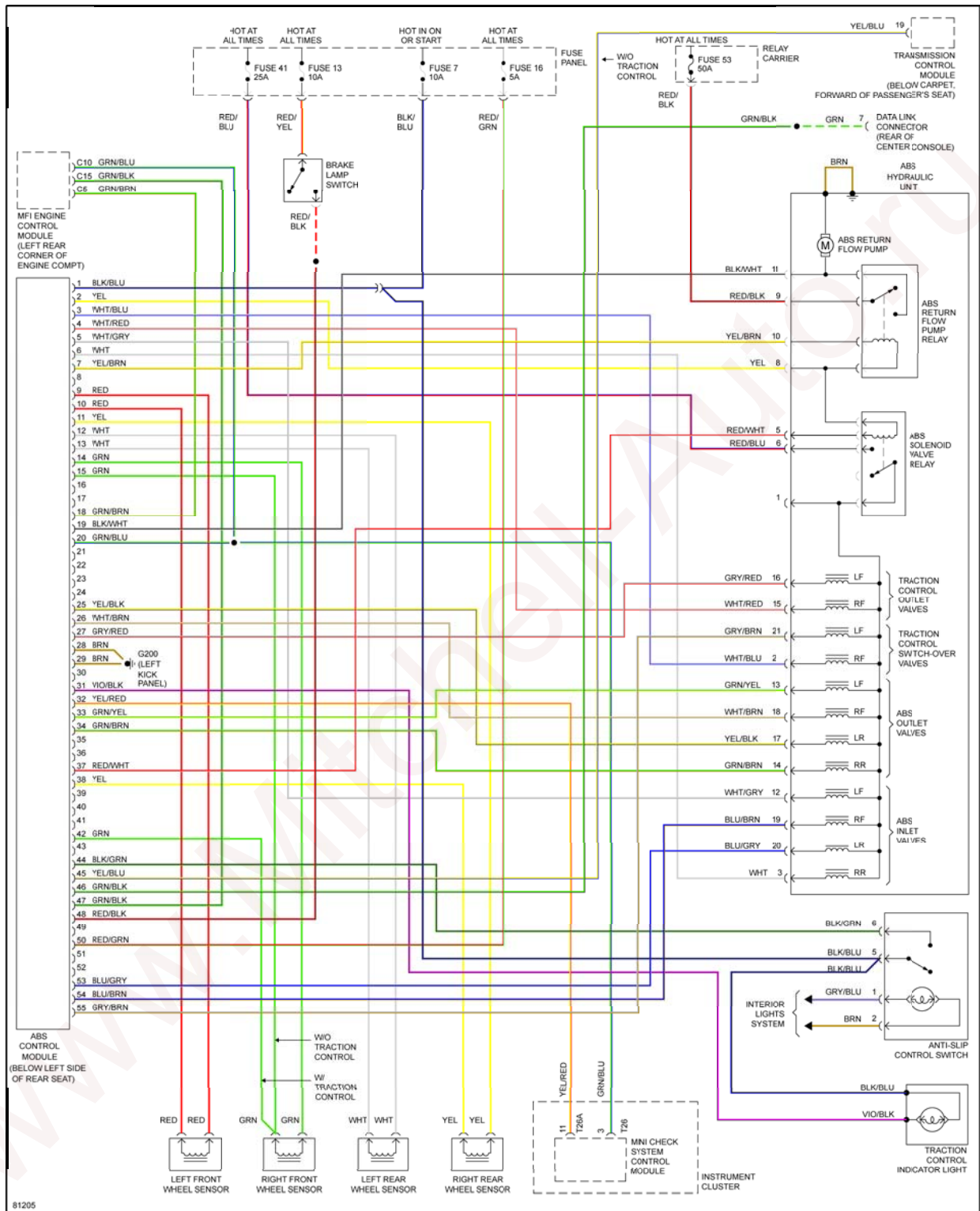

Fig. 3: Anti-Lock Brake System Wiring Diagram (1994 S320 & S350 Circuit, FWD Without Acceleration)

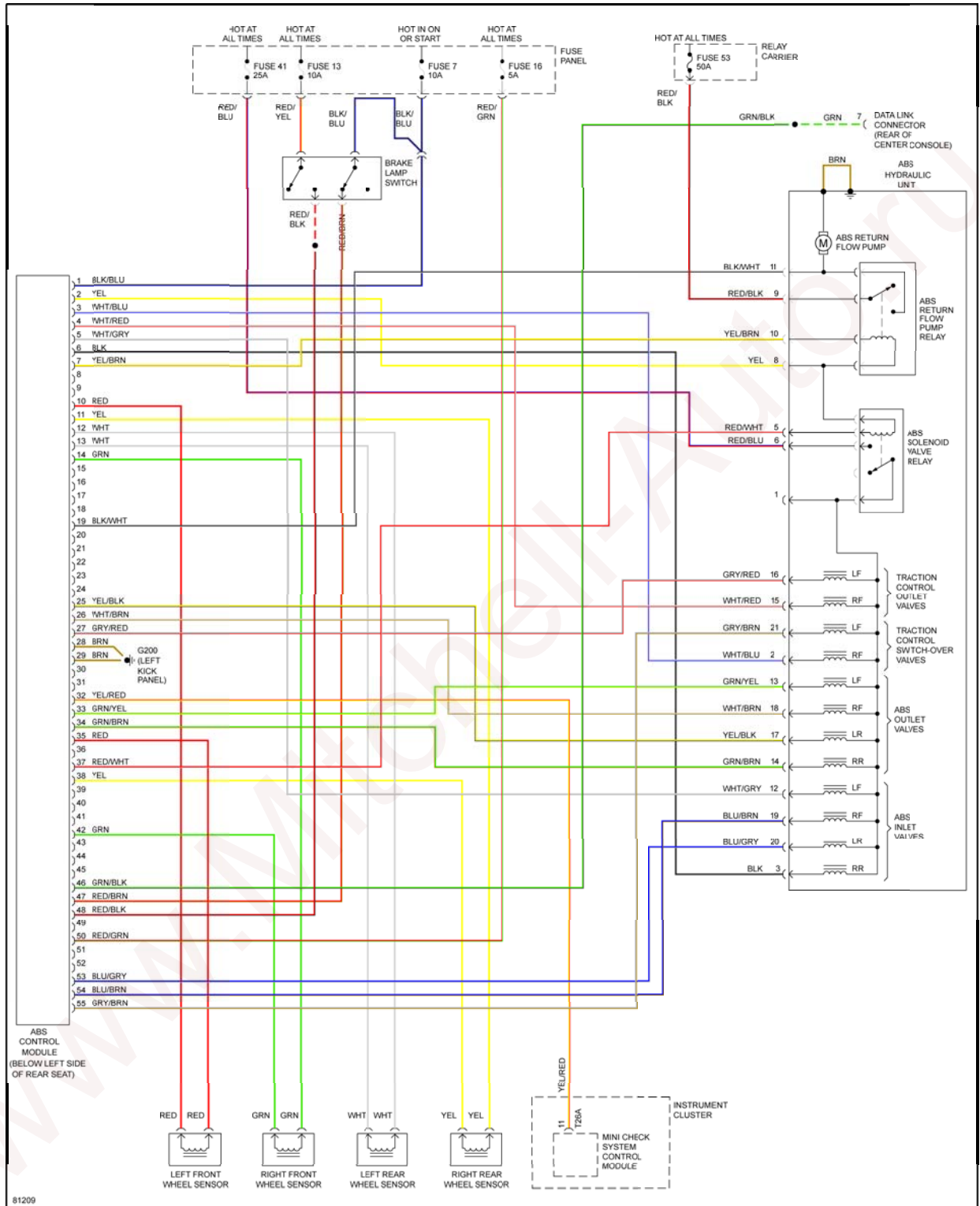

Fig. 4: Anti-lock Brakes Circuit, Quattro

ANTI-THEFT

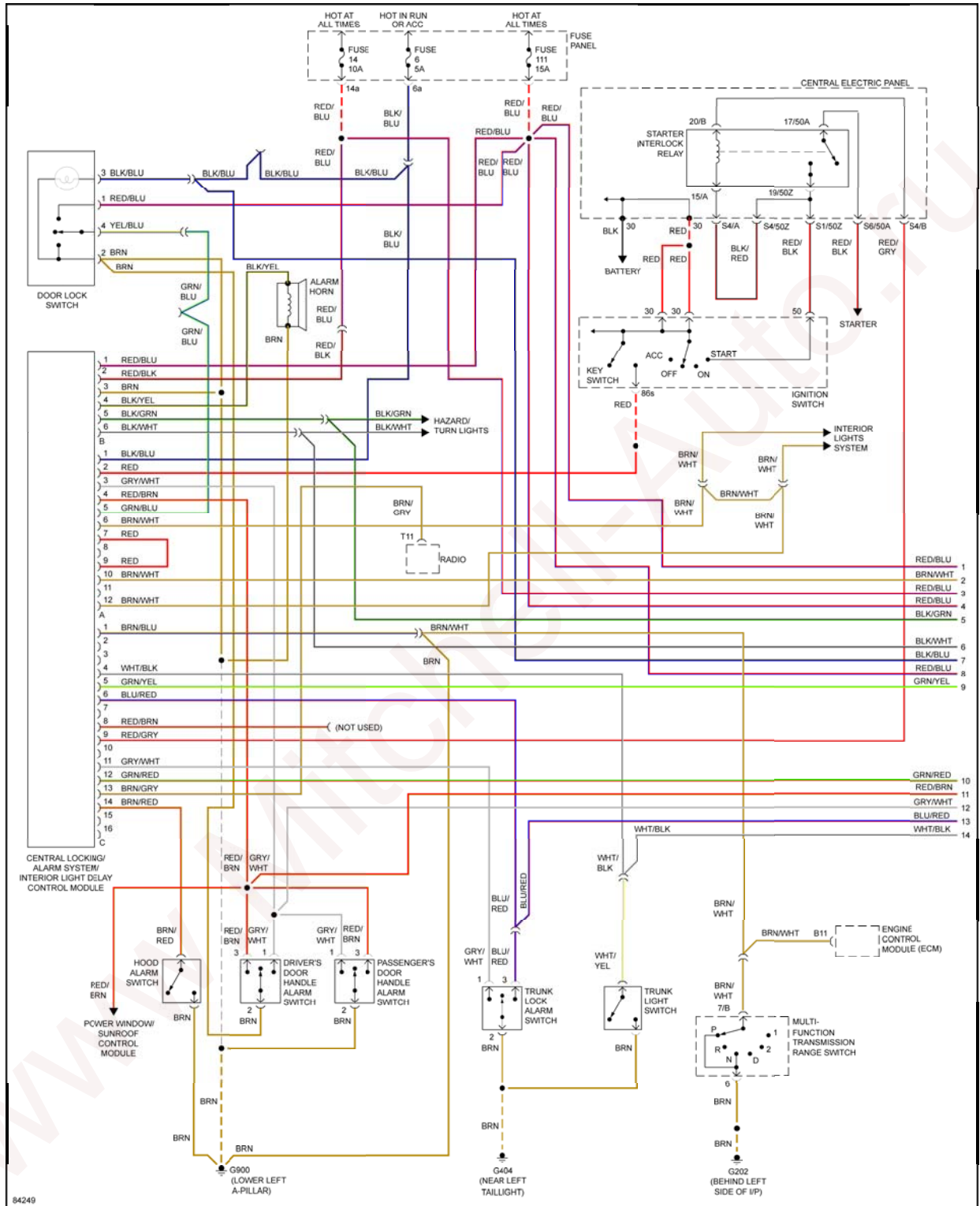

Fig. 5: Anti-theft & Central Locking Circuit (1 of 2)

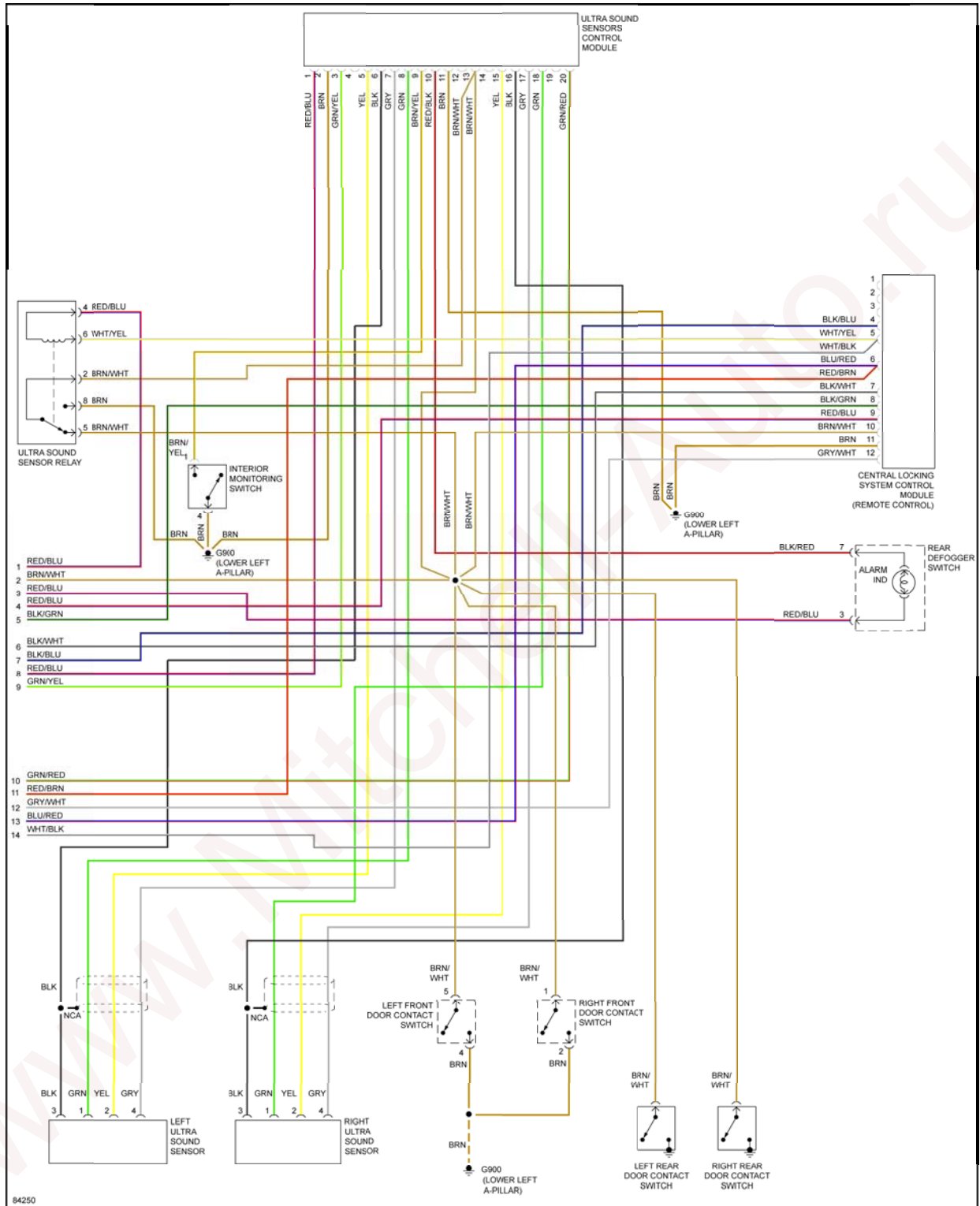

Fig. 6: Anti-theft & Central Locking Circuit (2 of 2)

COMPUTER DATA LINES

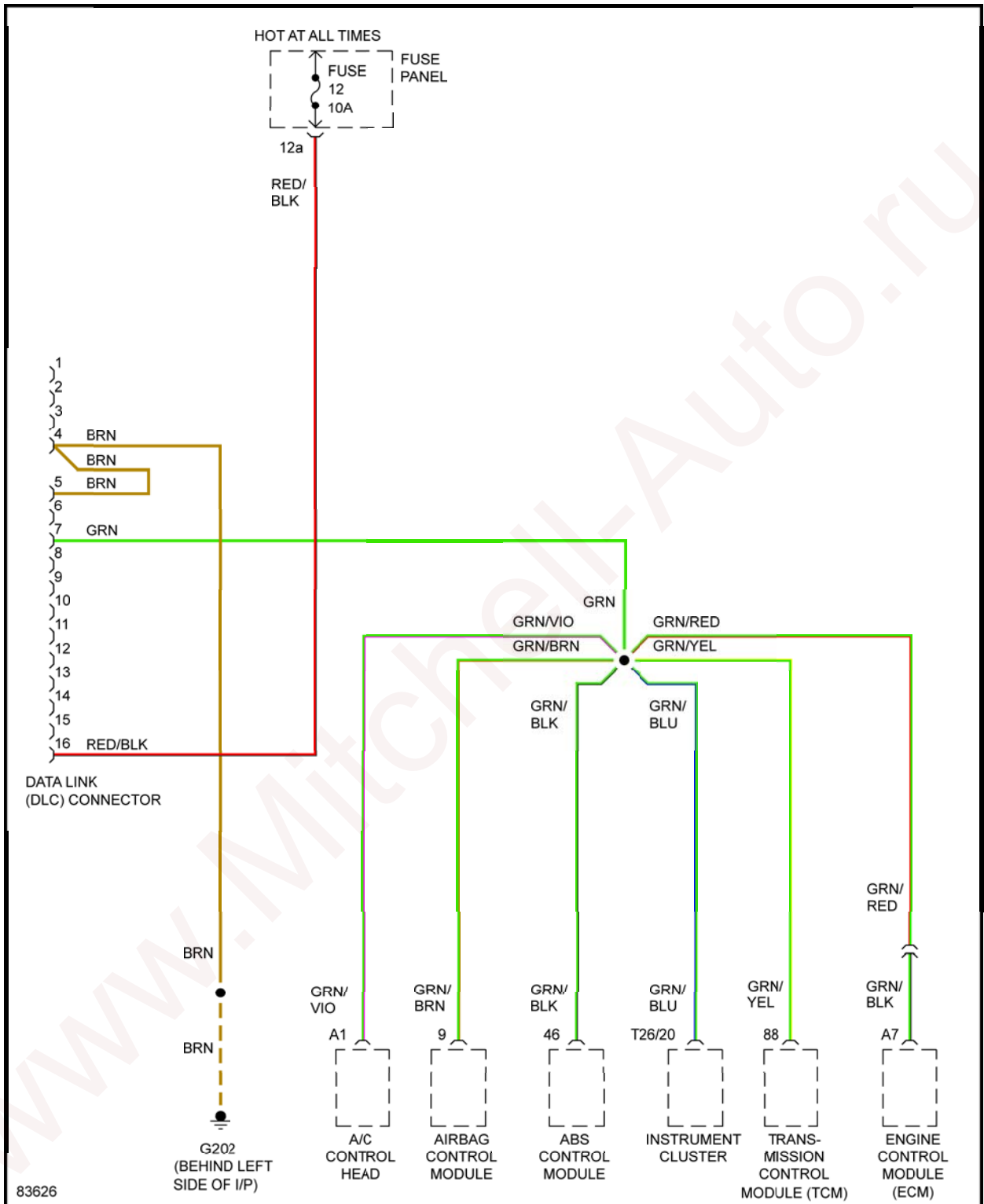

Fig. 7: Computer Data Lines Circuit

COOLING FAN

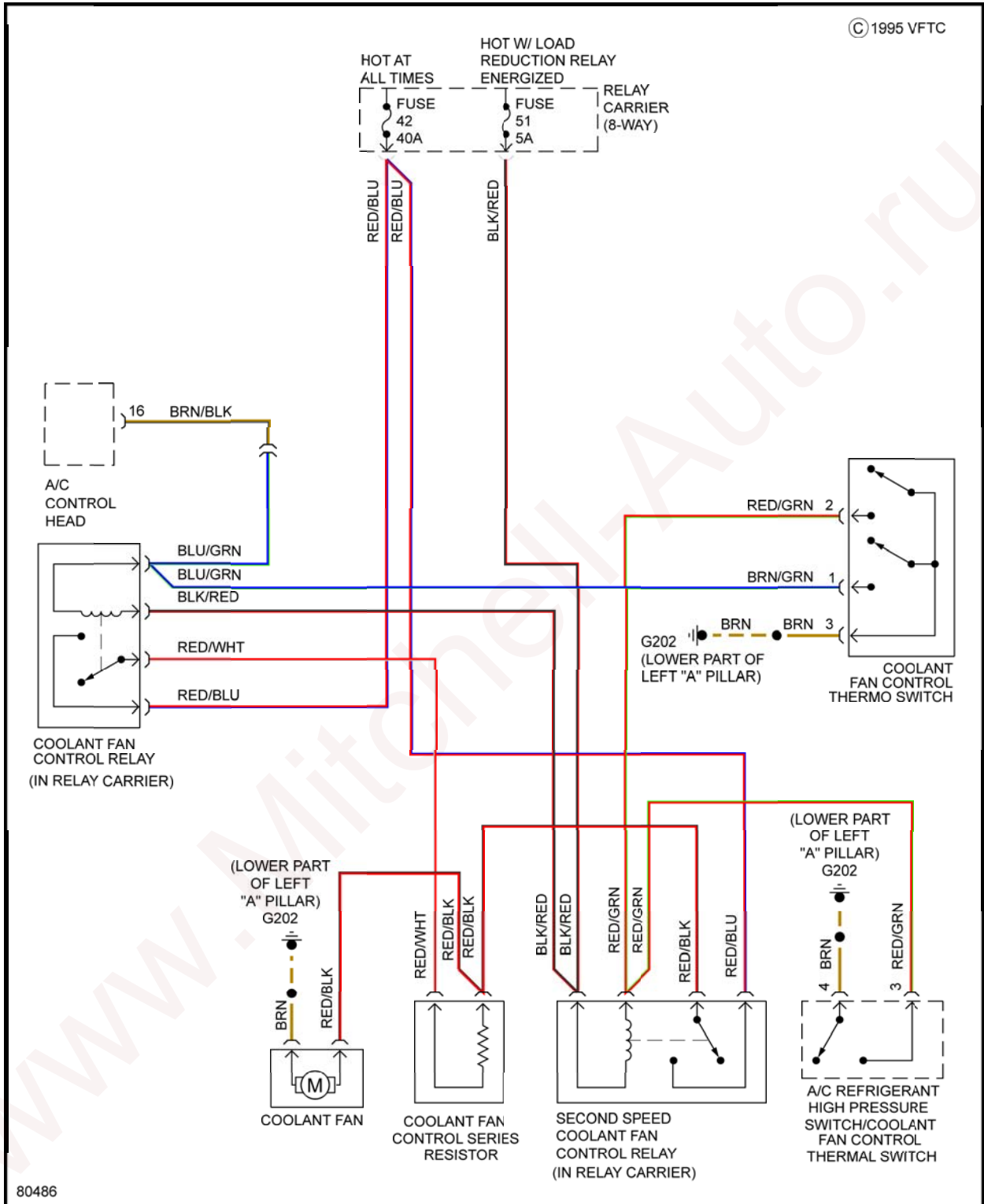

Fig. 8: Cooling Fan Circuit

CRUISE CONTROL

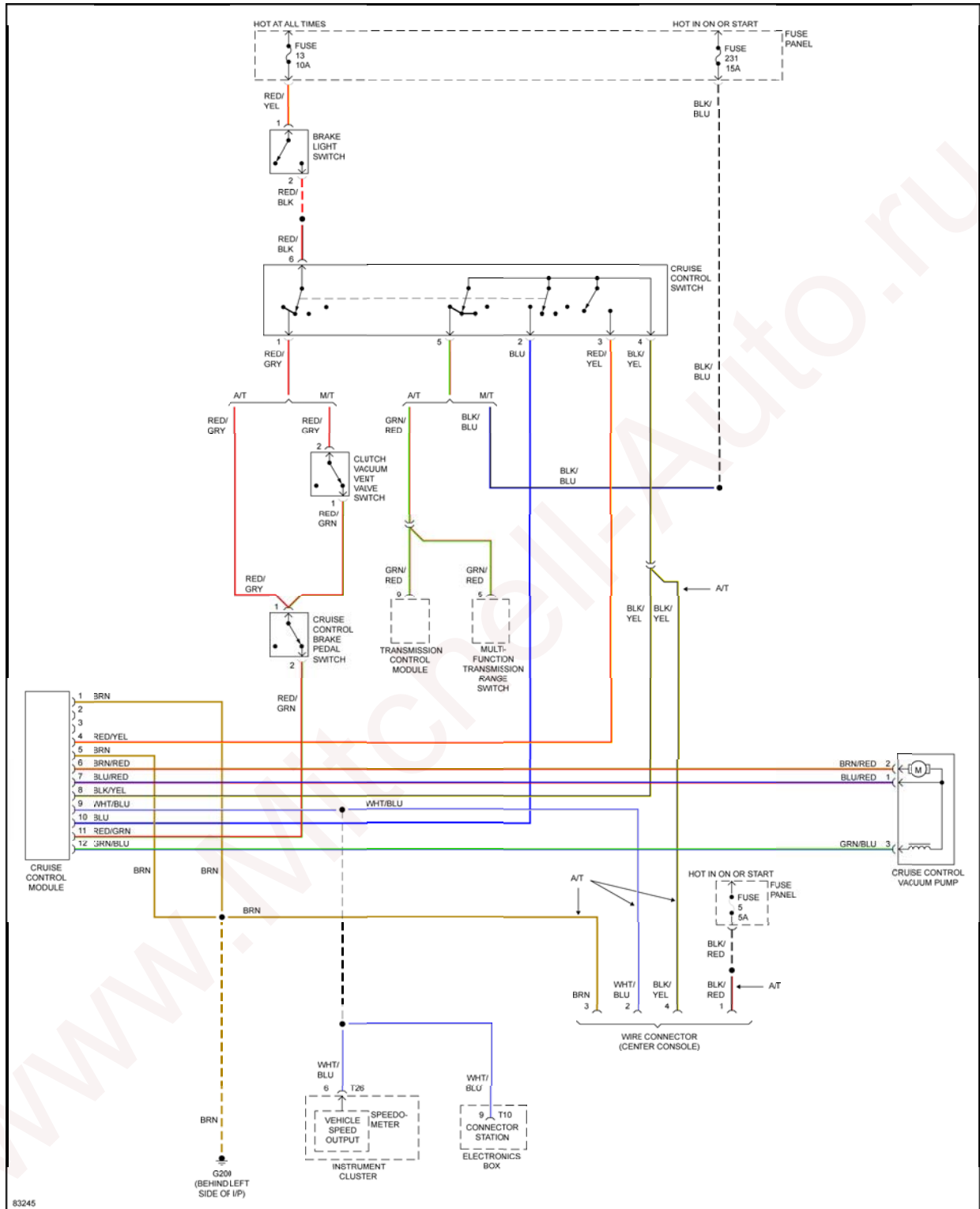

Fig. 9: Cruise Control Circuit

DEFOGGERS

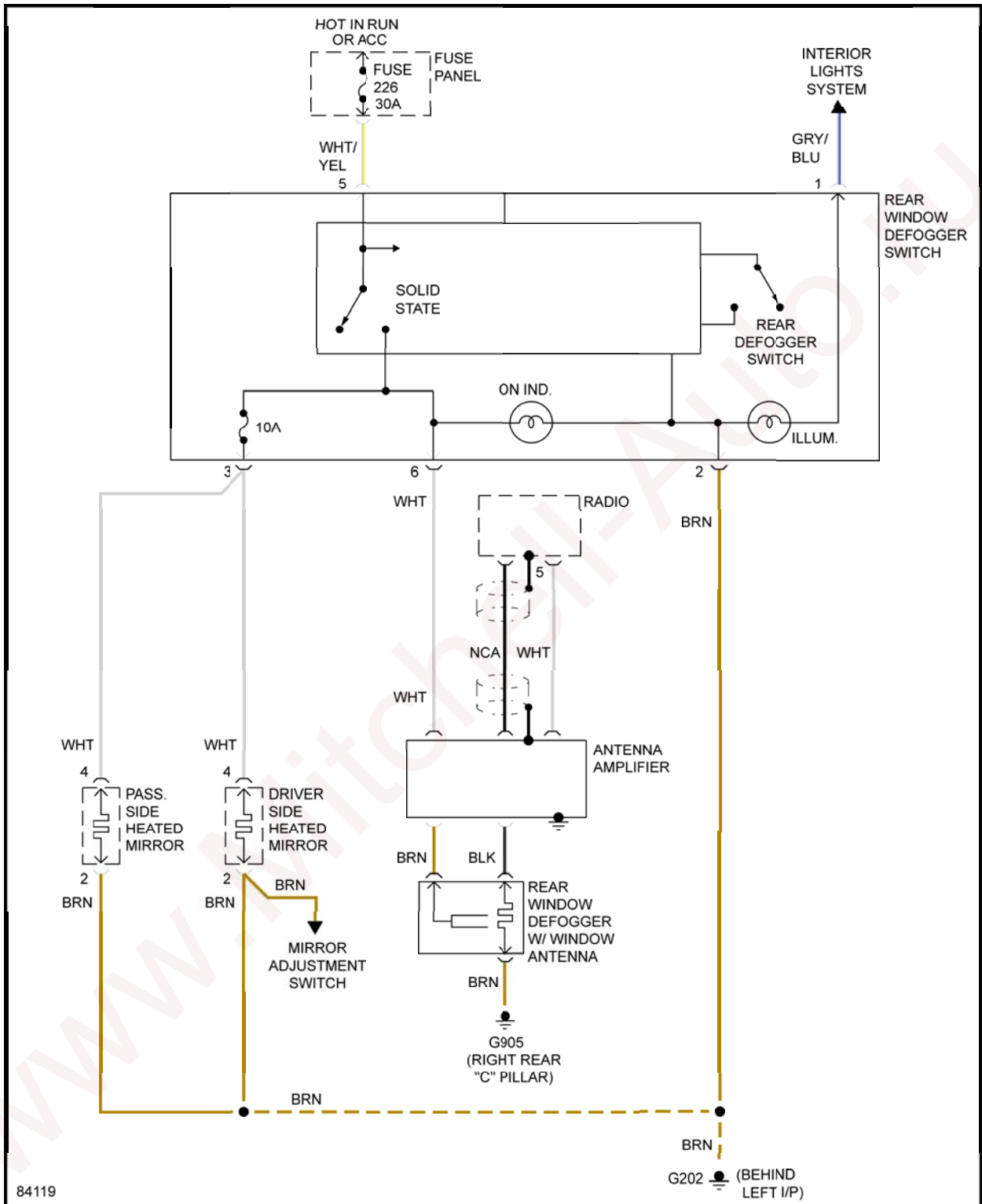

Fig. 10: W/ Antenna Amplifier Circuit

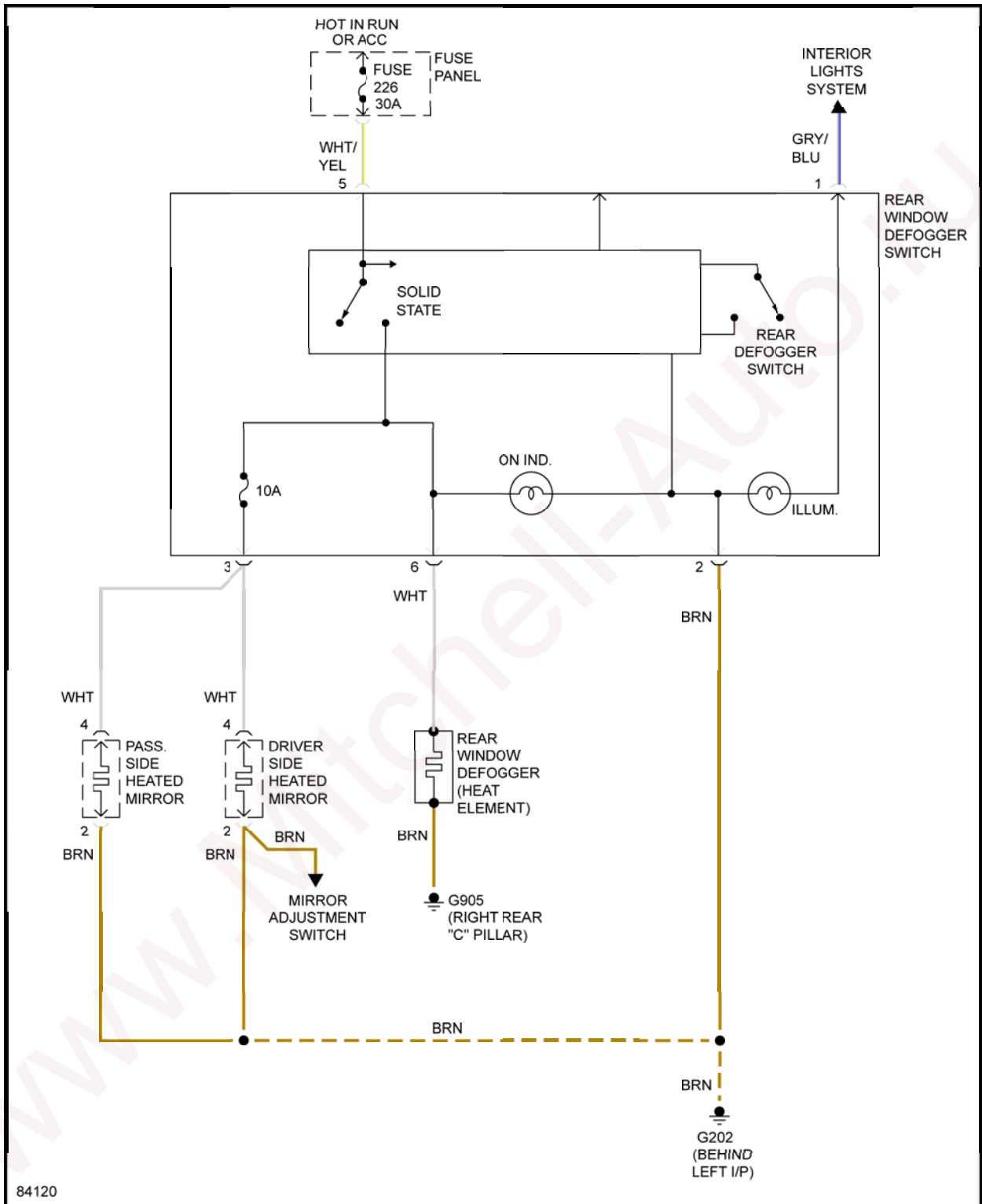

Fig. 11: W/O Antenna Amplifier Circuit

ENGINE PERFORMANCE

2.8L

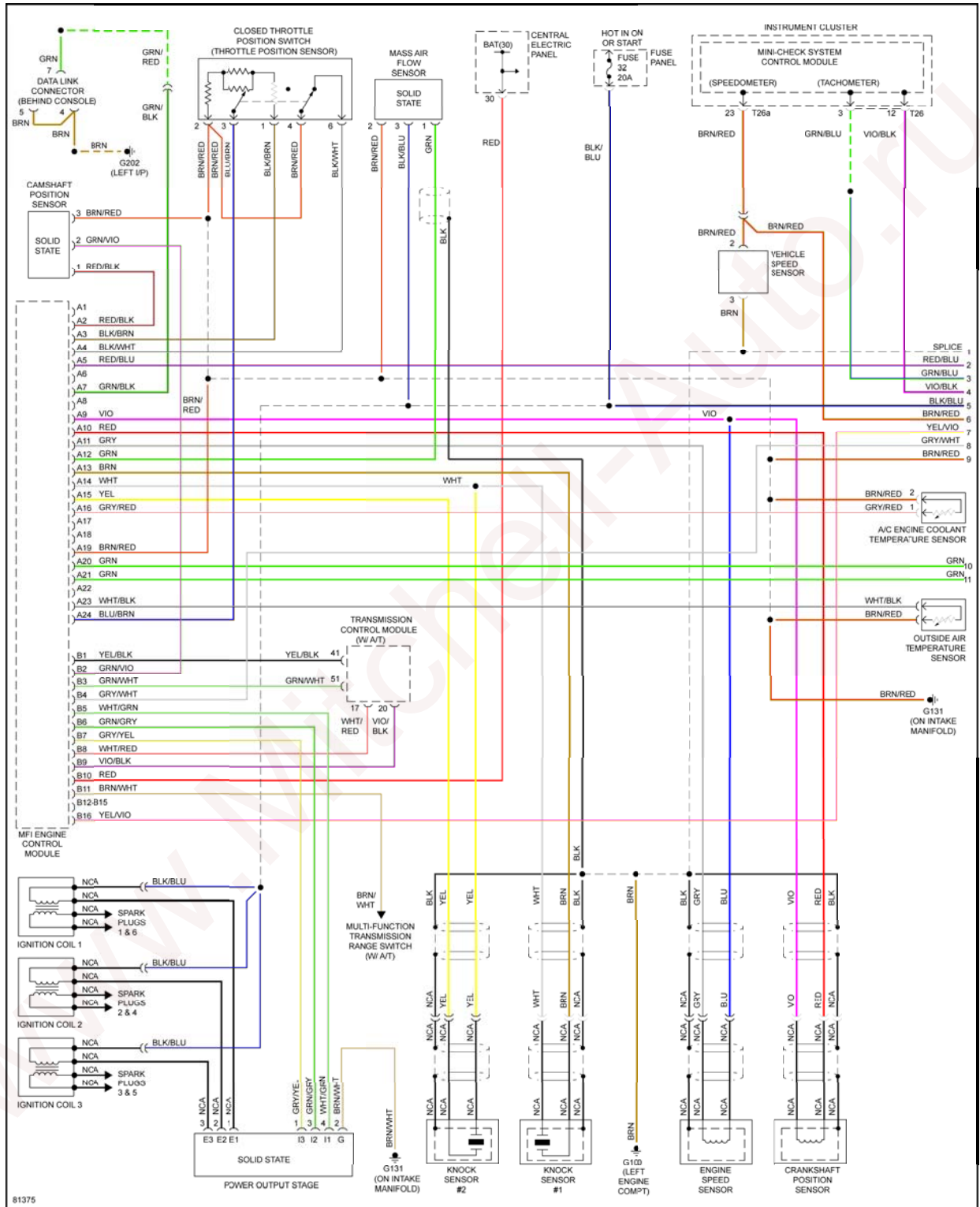

Fig. 12: 2.8L, Wiring Diagram (A4 2.8L Circuit 1 Of 2)

1996 Audi A4

SYSTEM WIRING DIAGRAMS Audi - A4

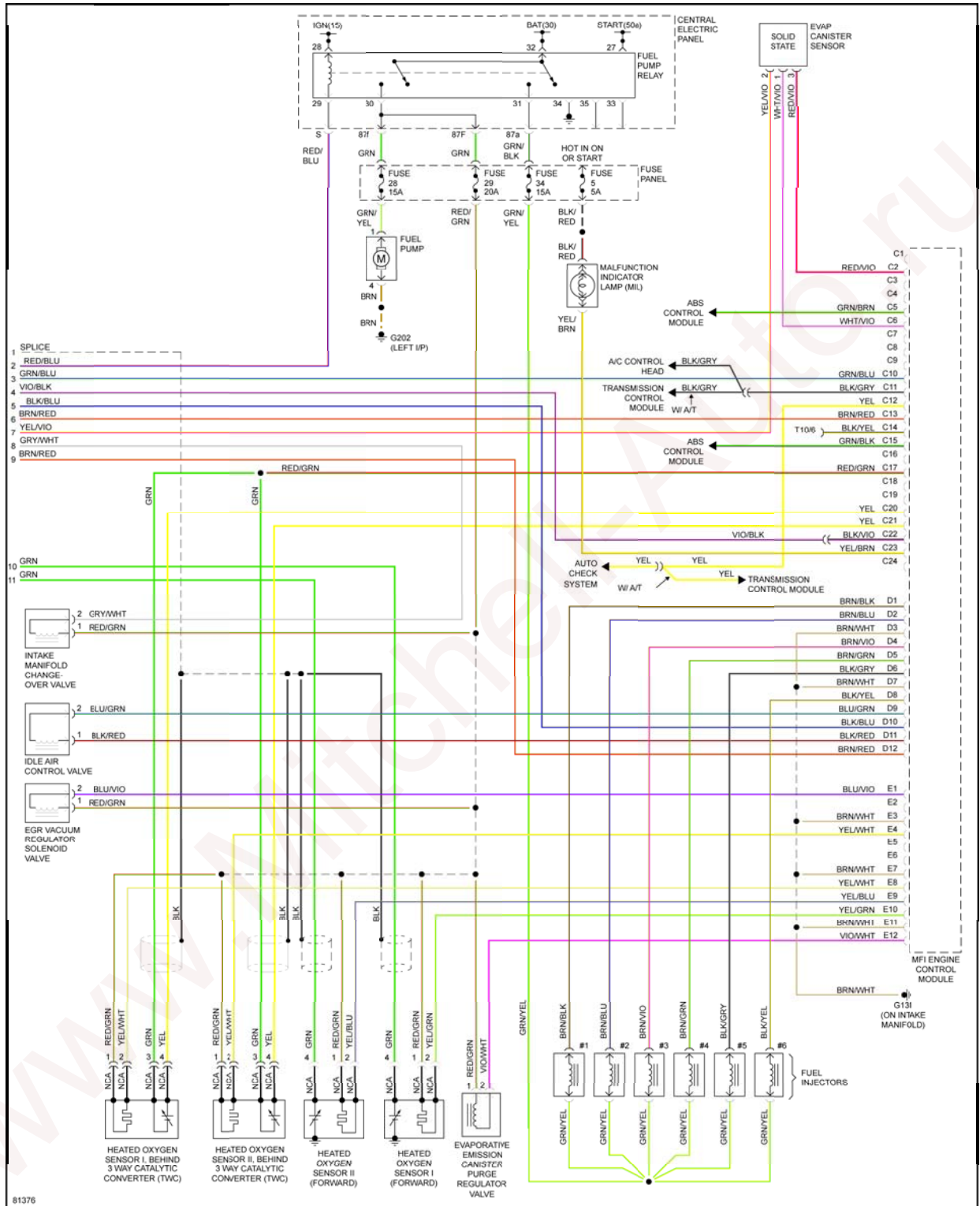

Fig. 13: 2.8L, Wiring Diagram (A4 2.8L Circuit 2 Of 2)

EXTERIOR LIGHTS

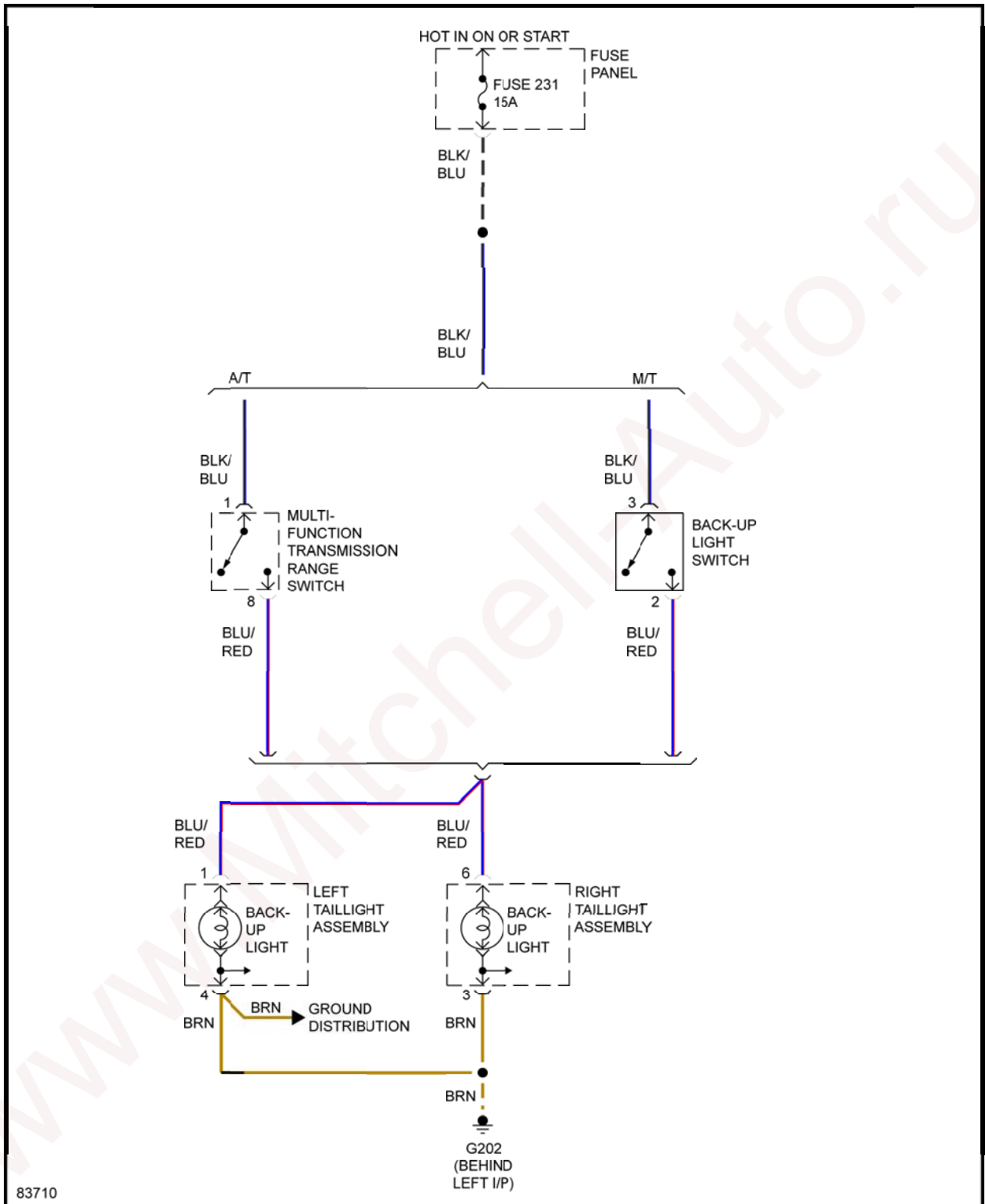

Fig. 14: Back-up Lamps Circuit

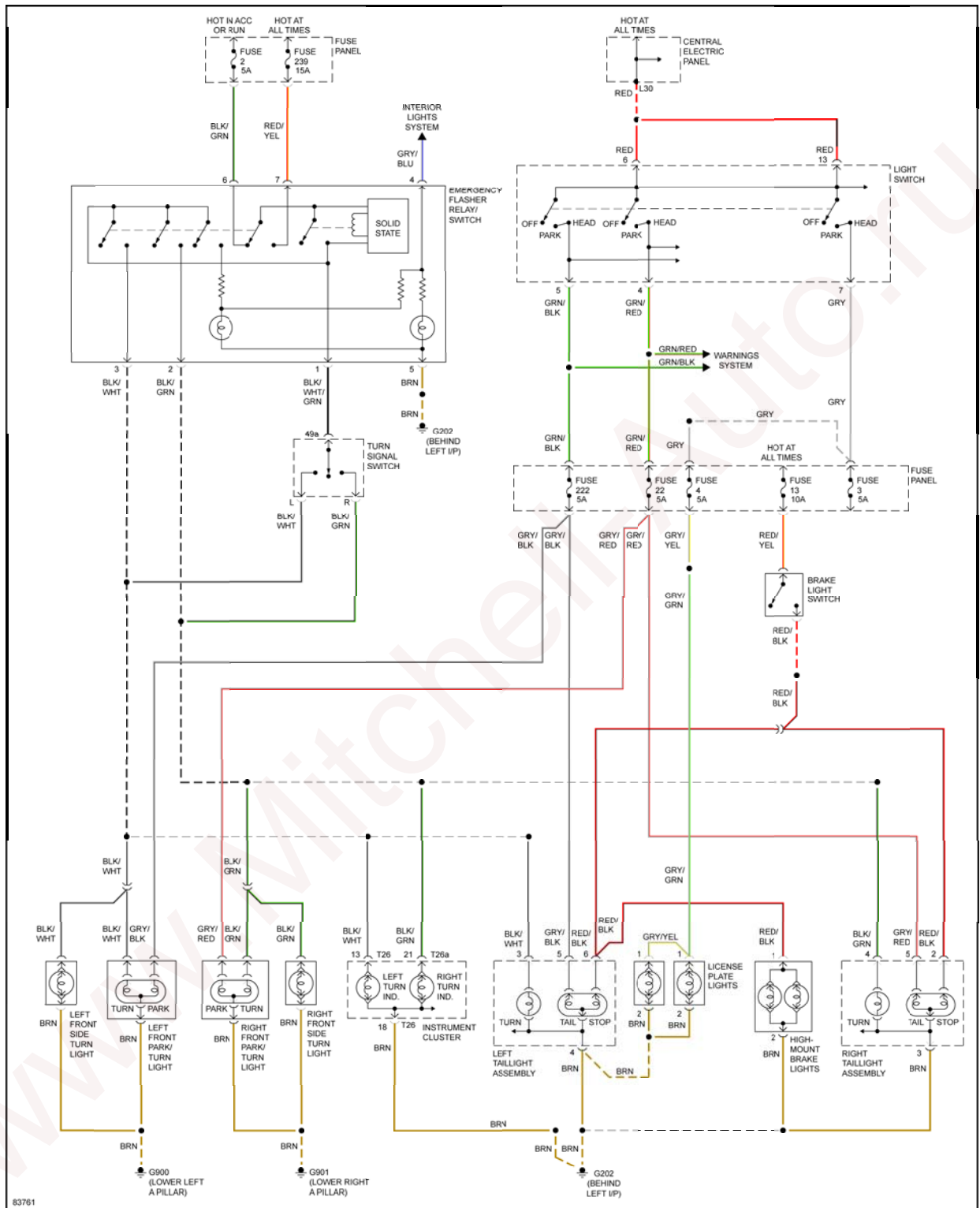

Fig. 15: Exterior Lamps Circuit

GROUND DISTRIBUTION

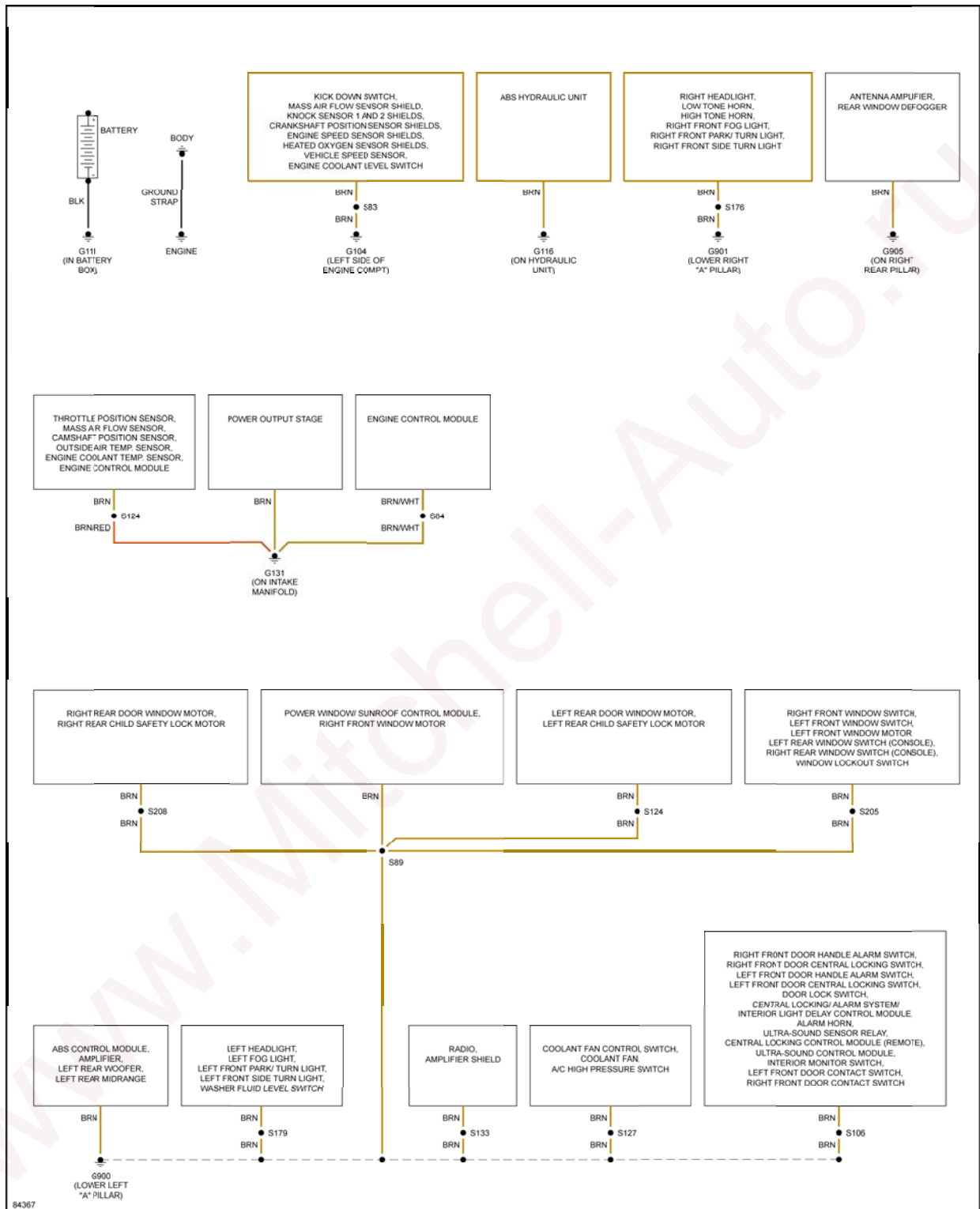

Fig. 16: Ground Distribution Circuit (1 of 2)

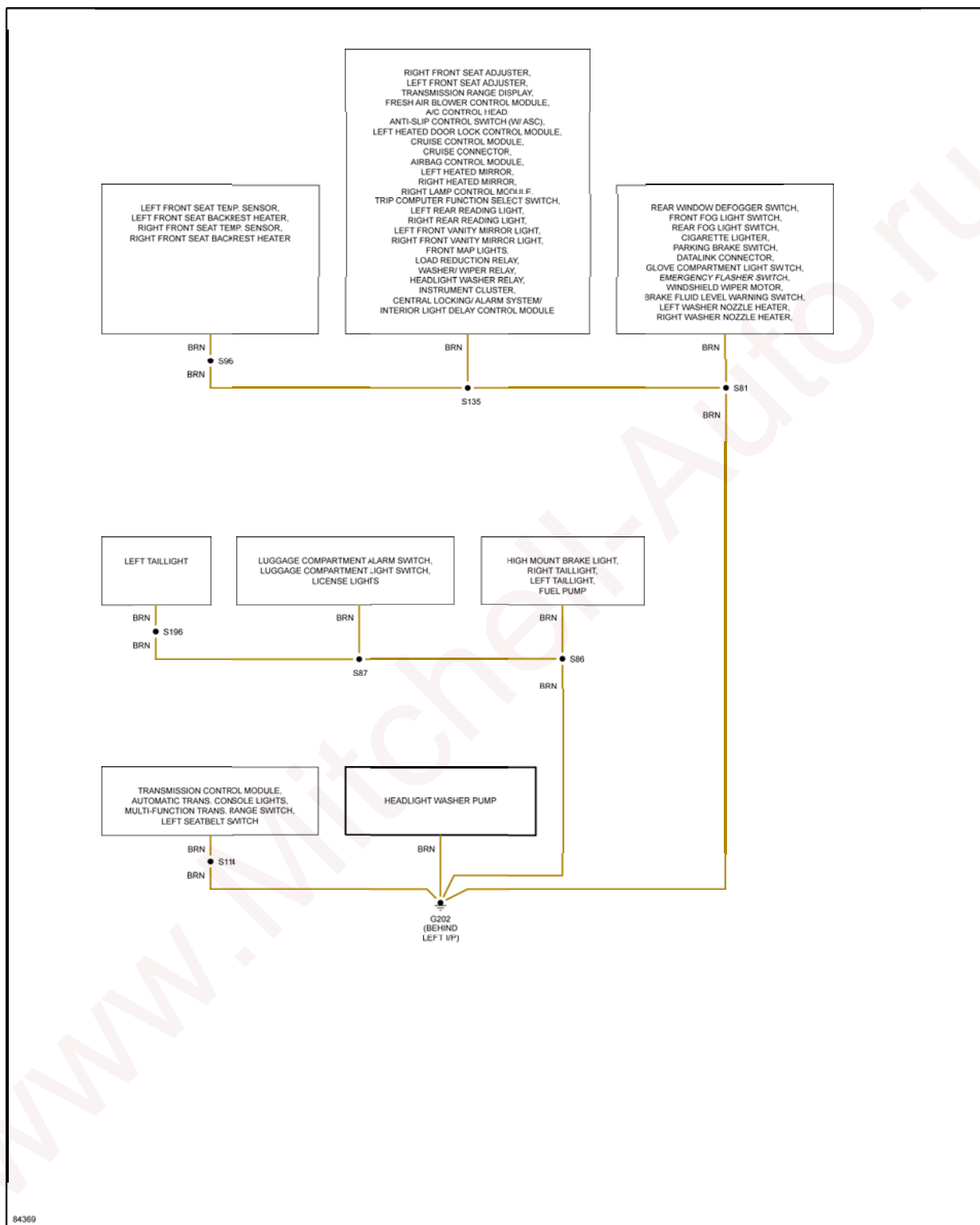

Fig. 17: Ground Distribution Circuit (2 of 2)

HEADLIGHTS

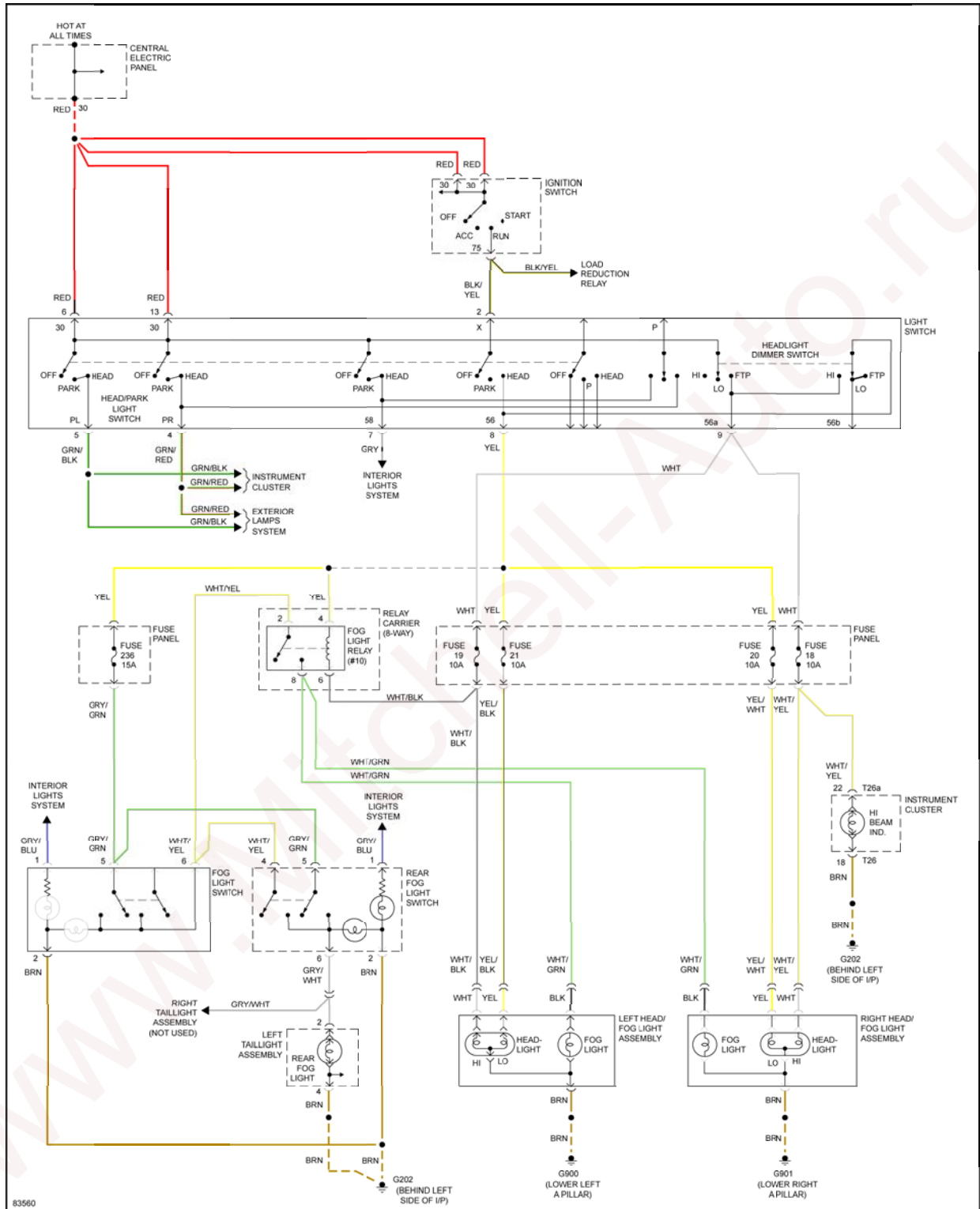

Fig. 18: Headlights Circuit

HORN

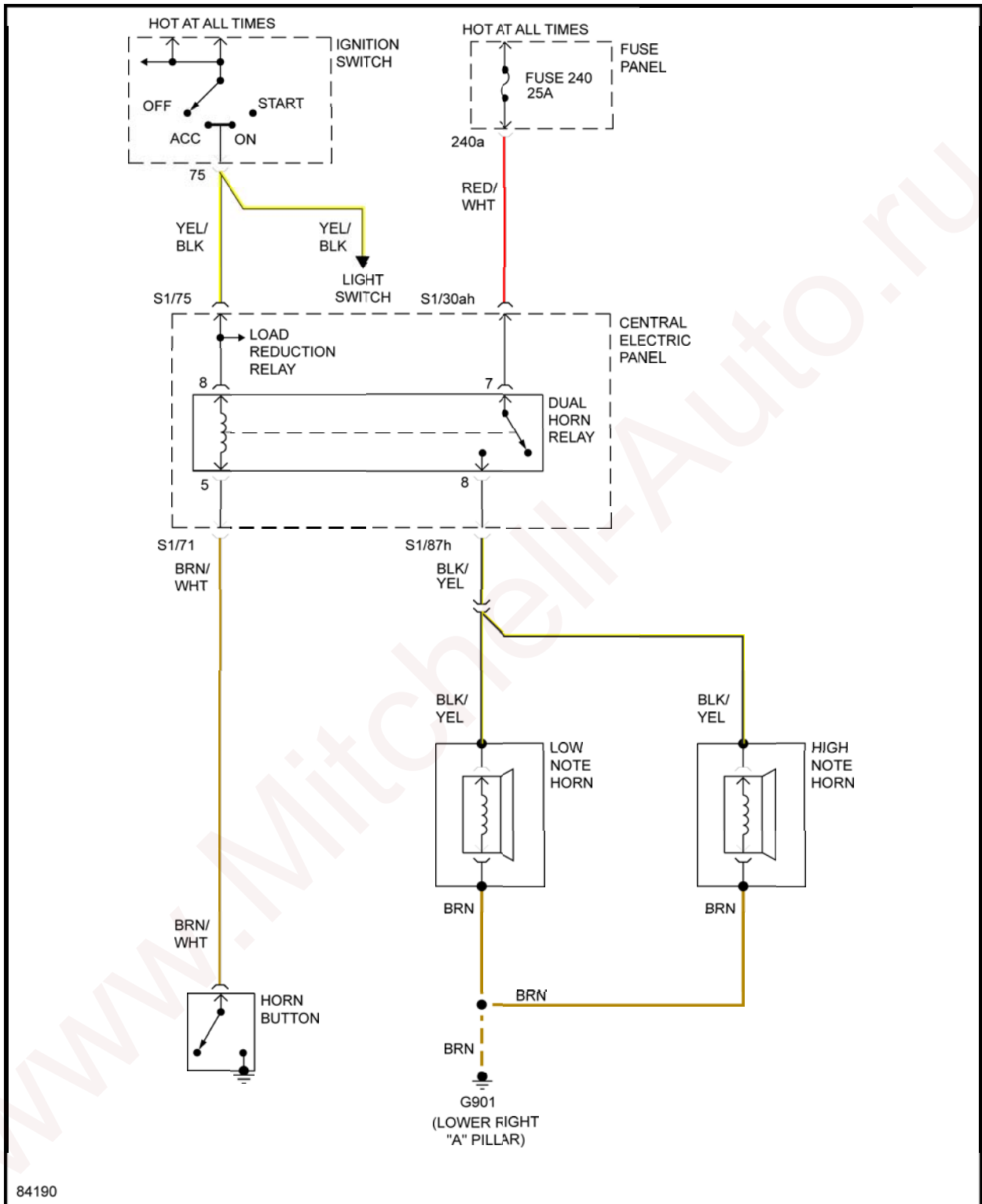

Fig. 19: Horn Circuit

INSTRUMENT CLUSTER