

Fig. 20: Instrument Cluster Circuit

## INTERIOR LIGHTS

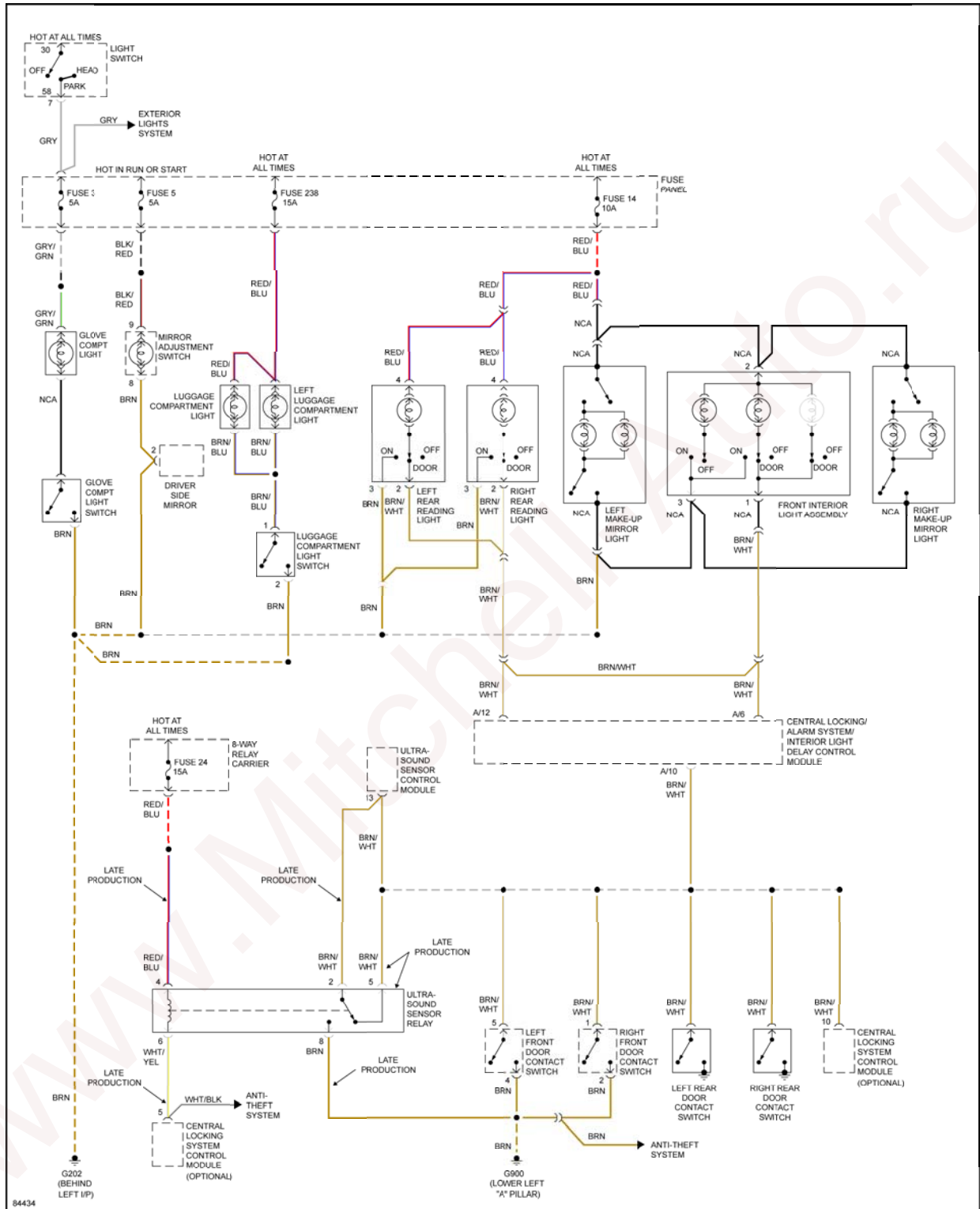

Fig. 21: Courtesy Lamps Circuit

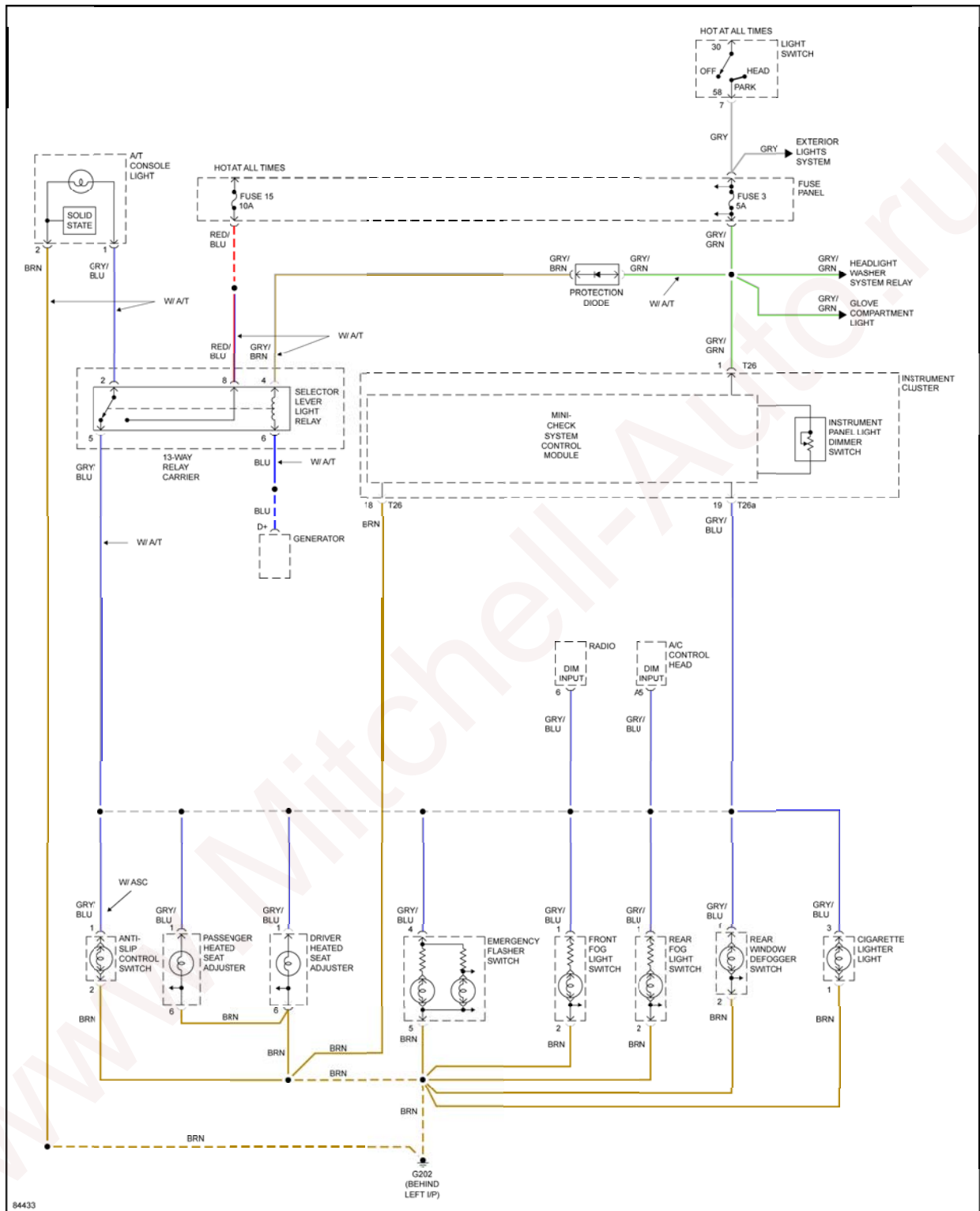

Fig. 22: Instrument Illumination Circuit

POWER DISTRIBUTION

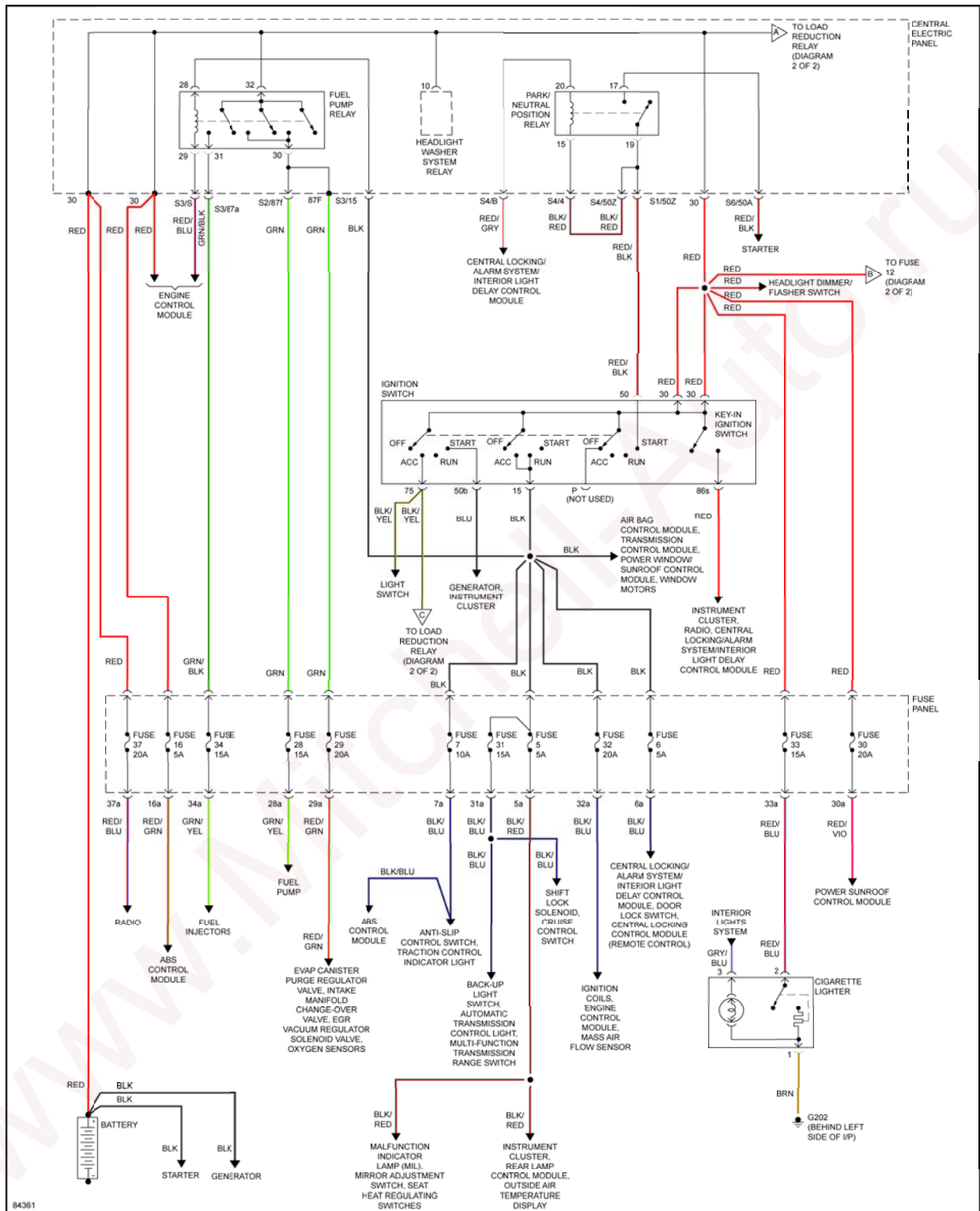

Fig. 23: Power Distribution Circuit (1 of 2)

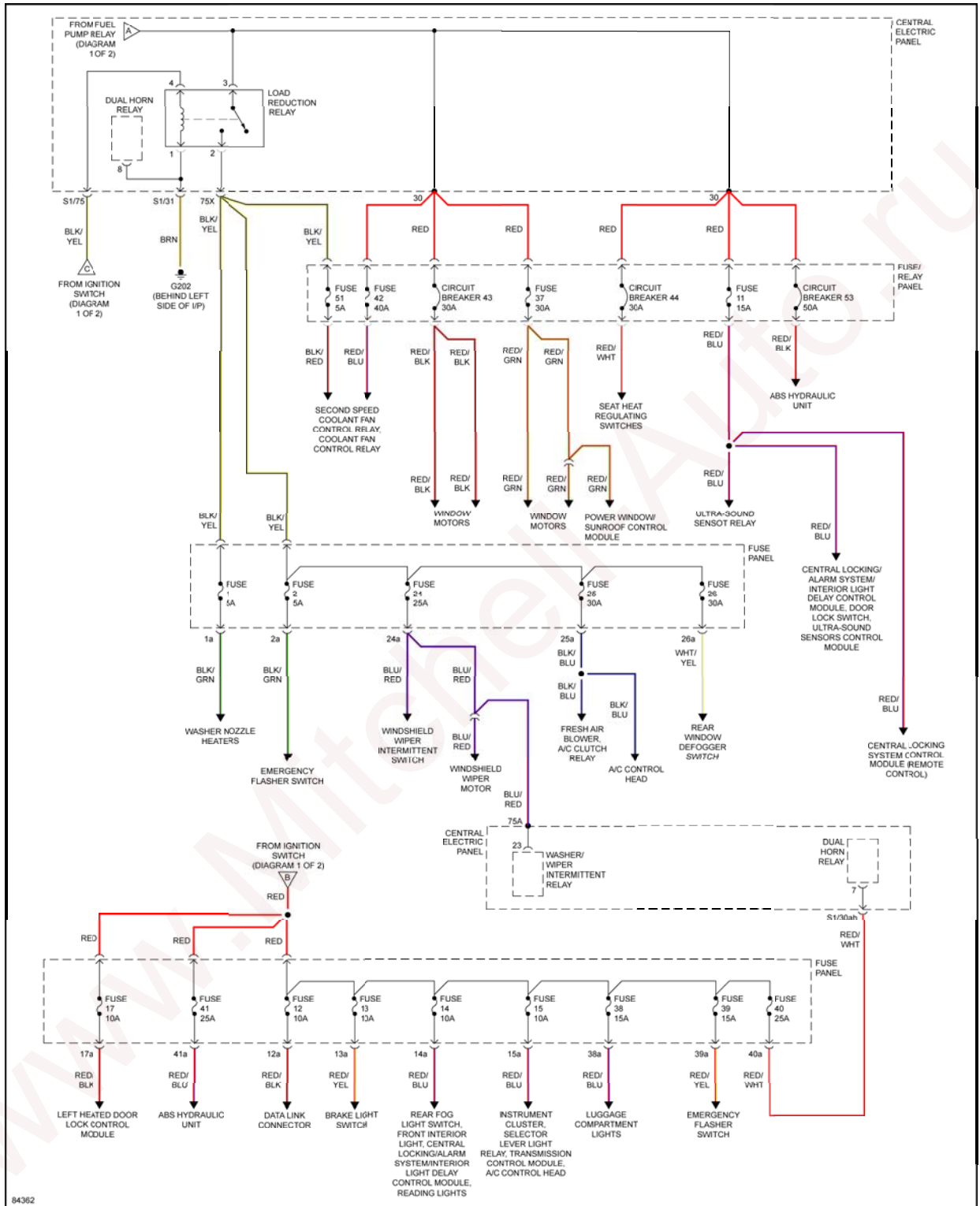
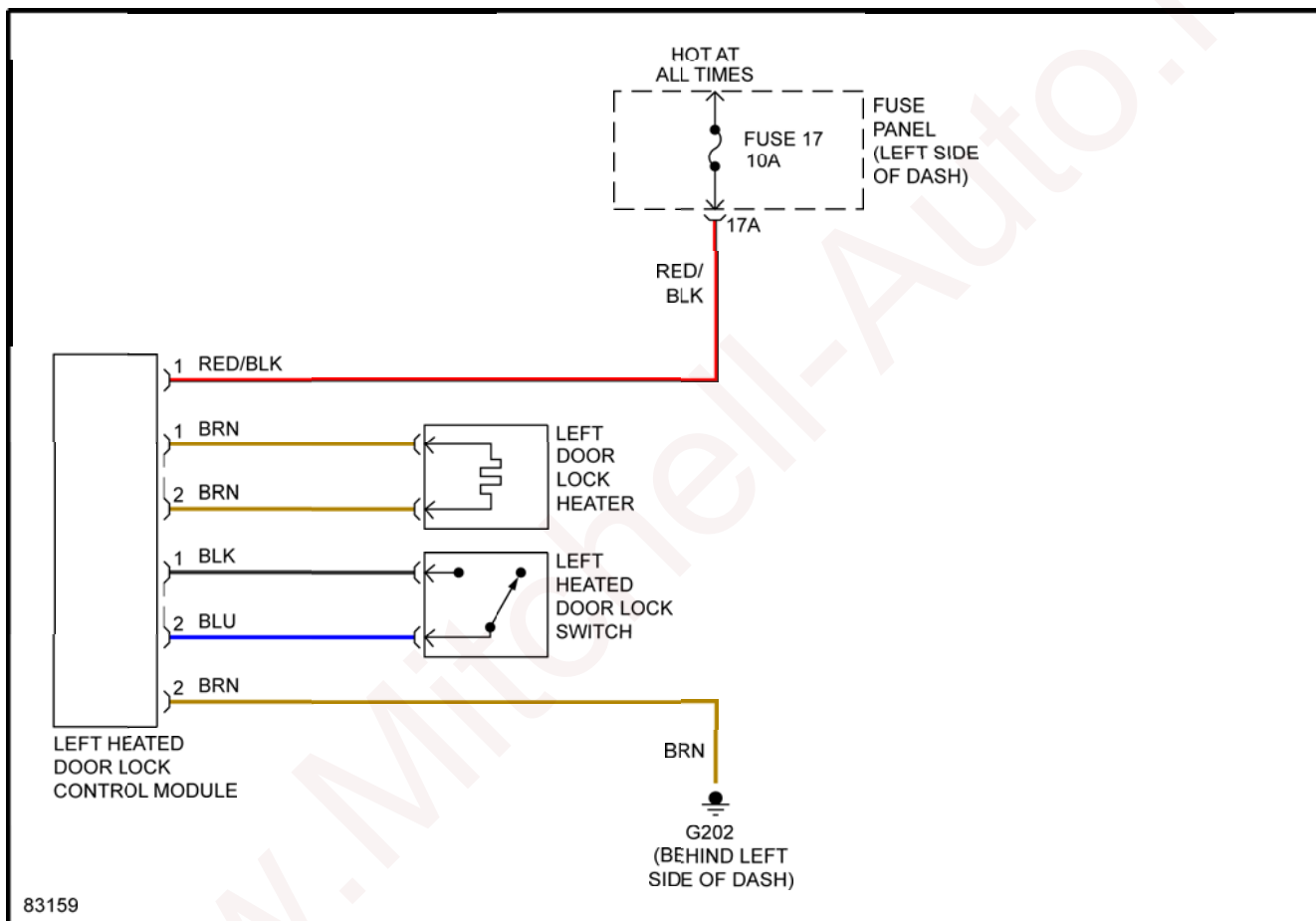

Fig. 24: Power Distribution Circuit (2 of 2)

## POWER DOOR LOCKS



**Fig. 25: Heated Door Locks Circuit**

**POWER MIRRORS**

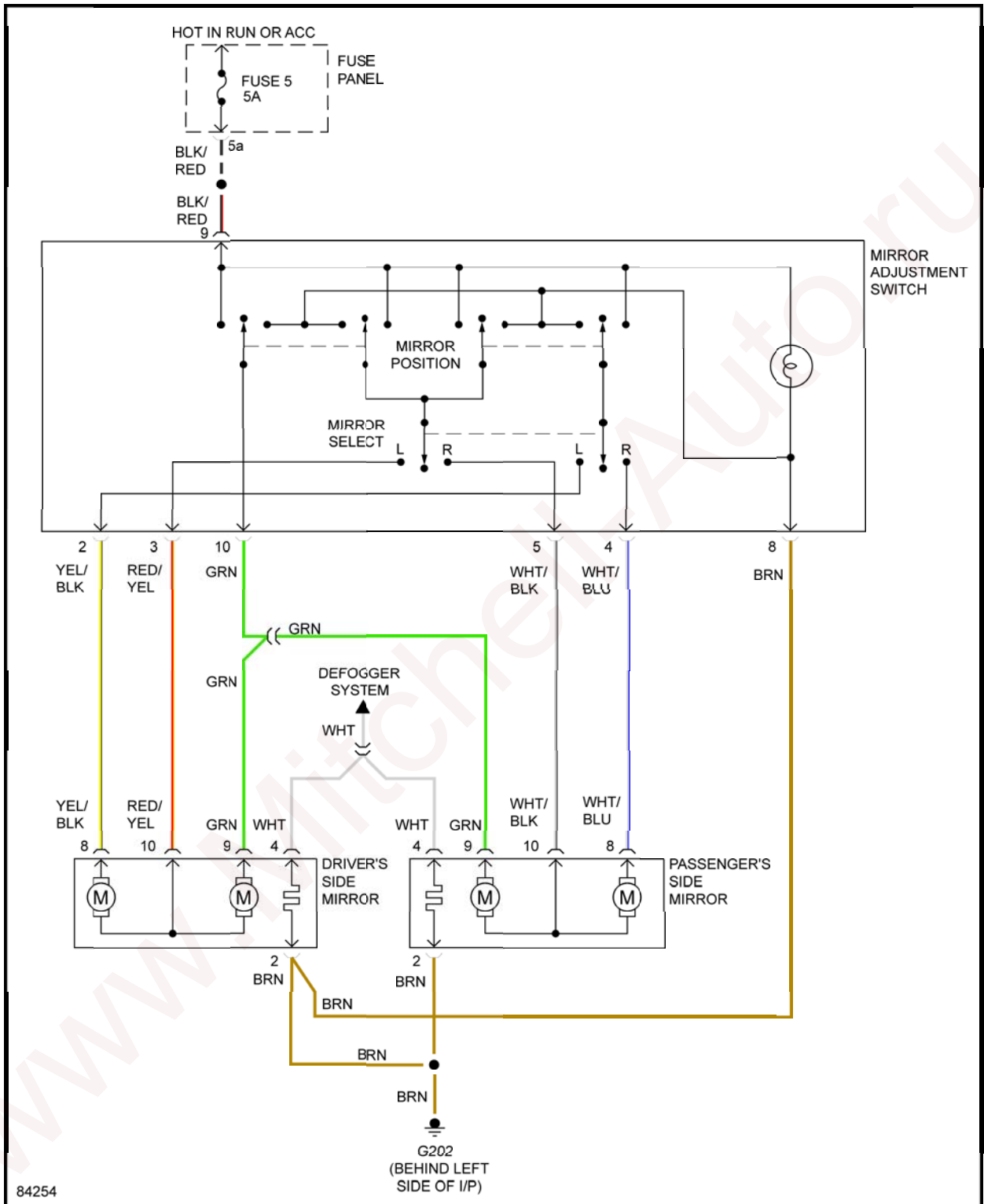

84254

Fig. 26: Power Mirrors Circuit

## POWER SEATS

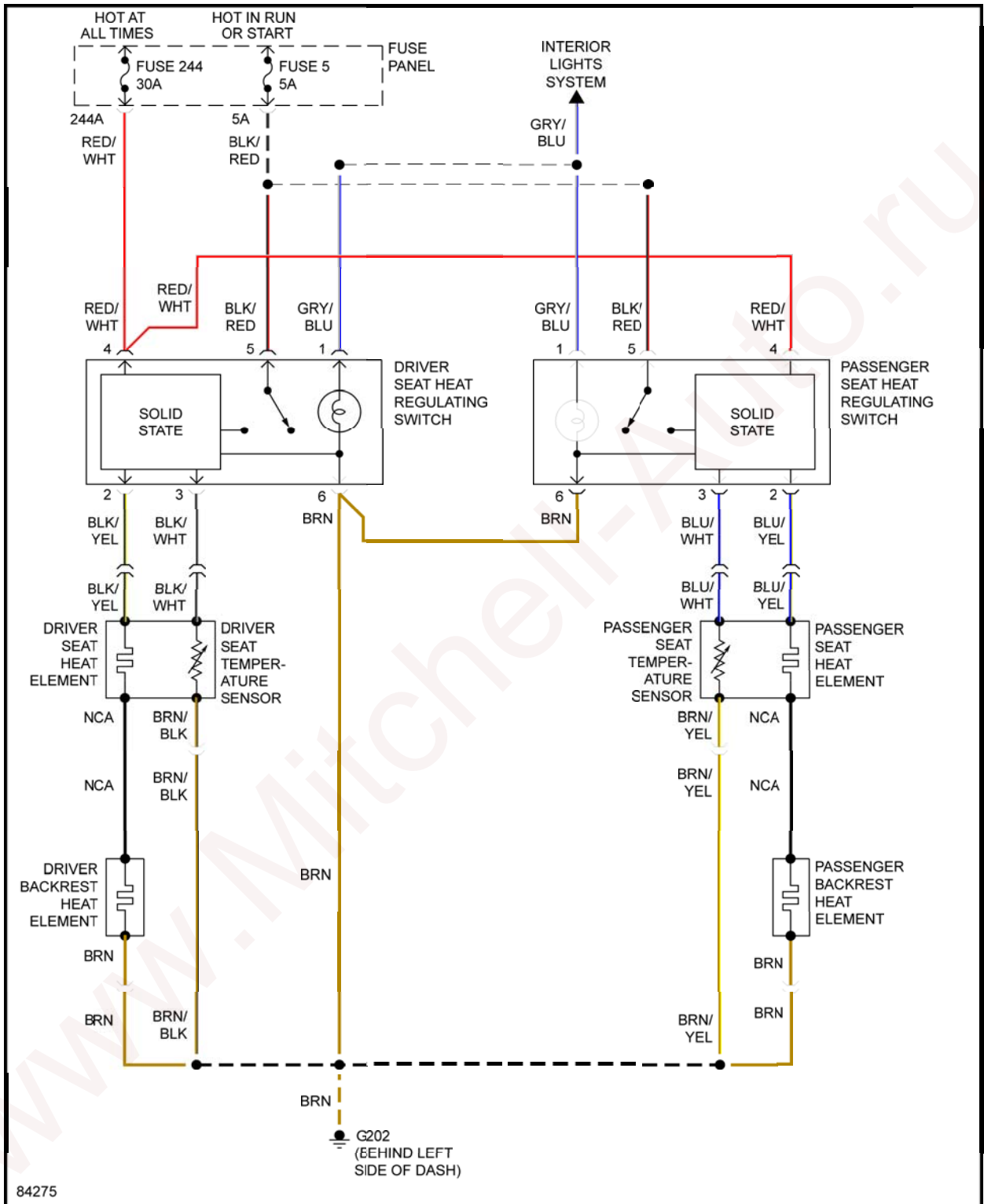

Fig. 27: Heated Seats Circuit



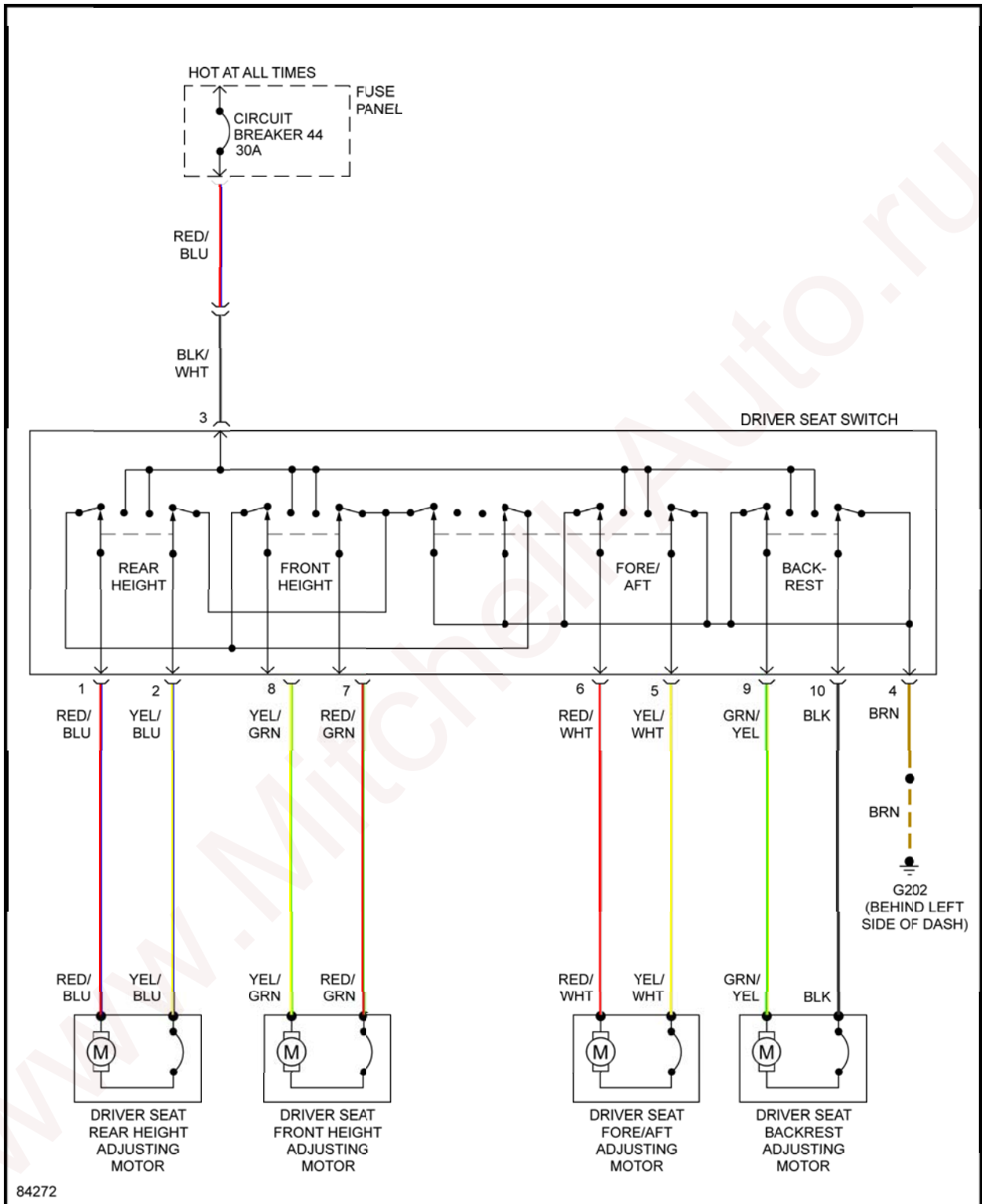
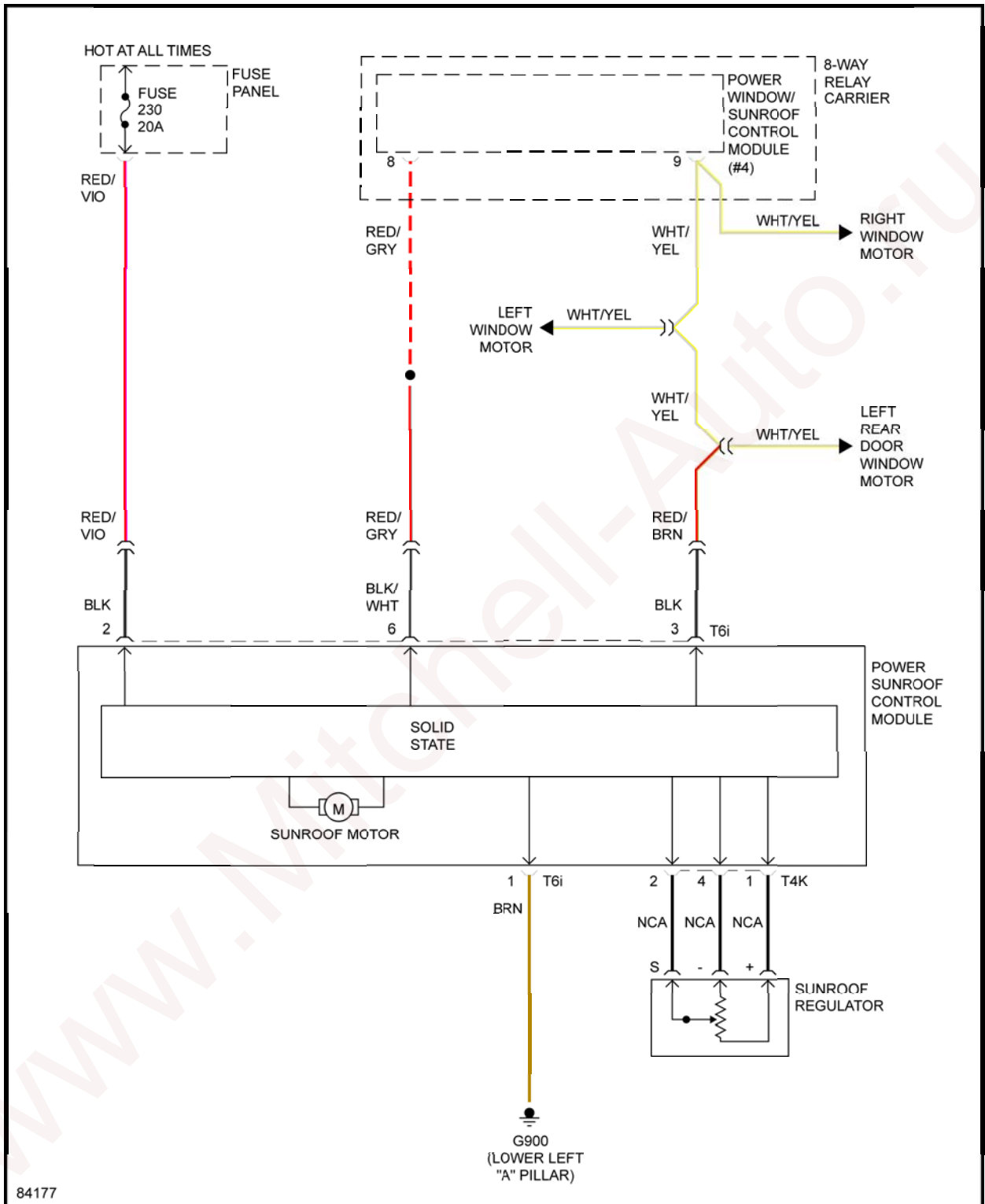

Fig. 28: Left Power Seat Circuit

POWER TOP/SUNROOF



84177

**Fig. 29: Sunroof Circuit**

**POWER WINDOWS**

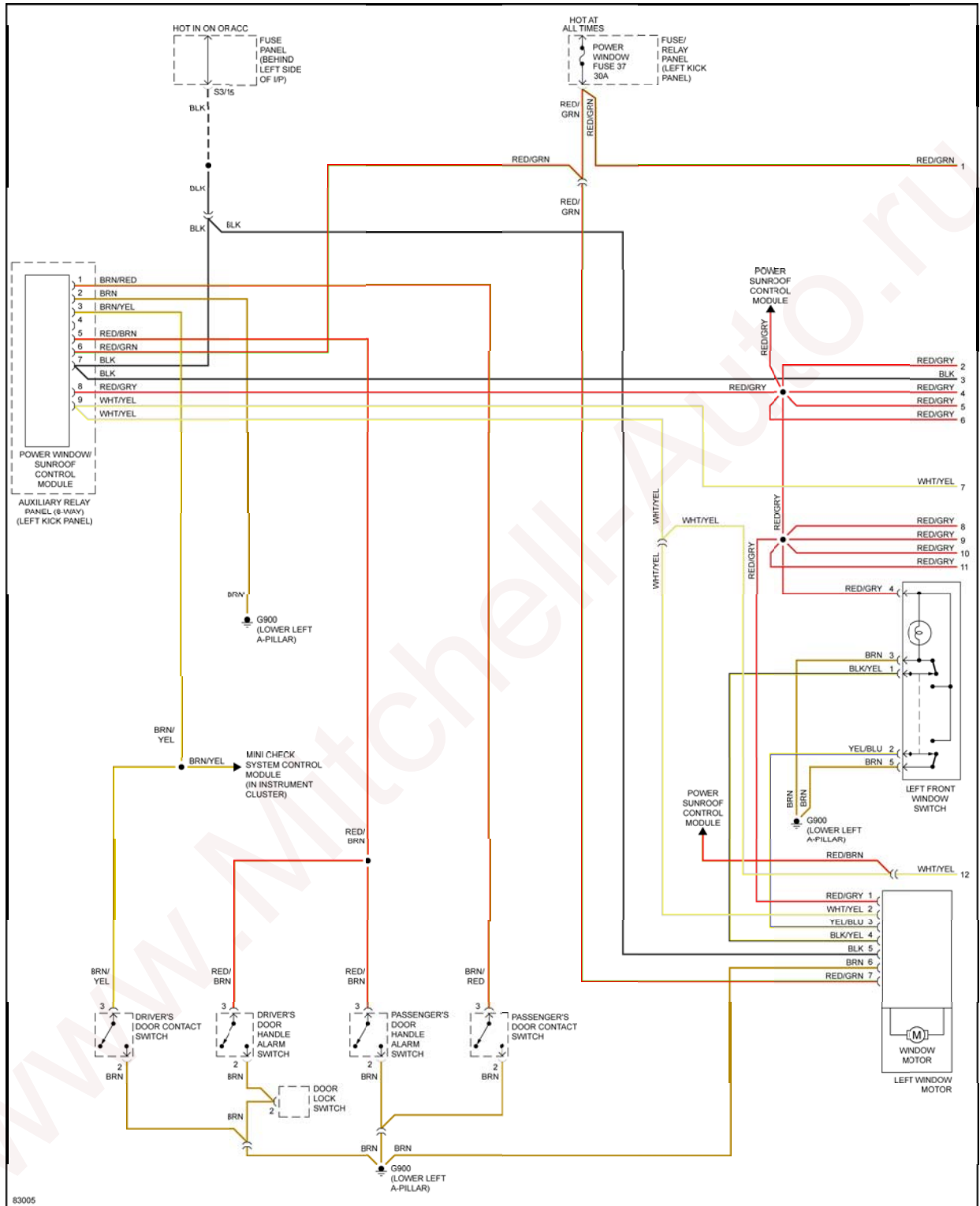

Fig. 30: Power Windows Circuit (1 of 2)

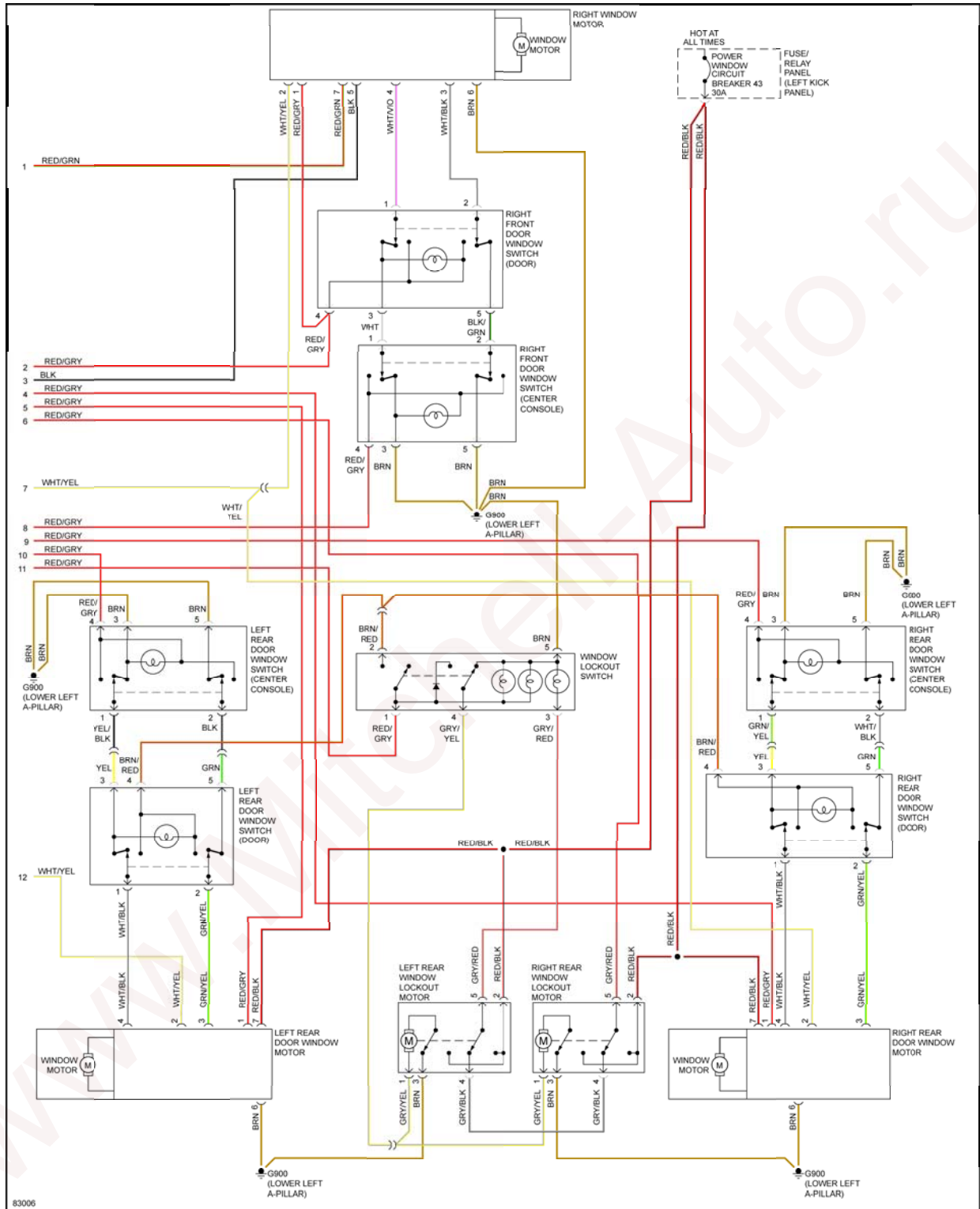

Fig. 31: Power Windows Circuit (2 of 2)

RADIO

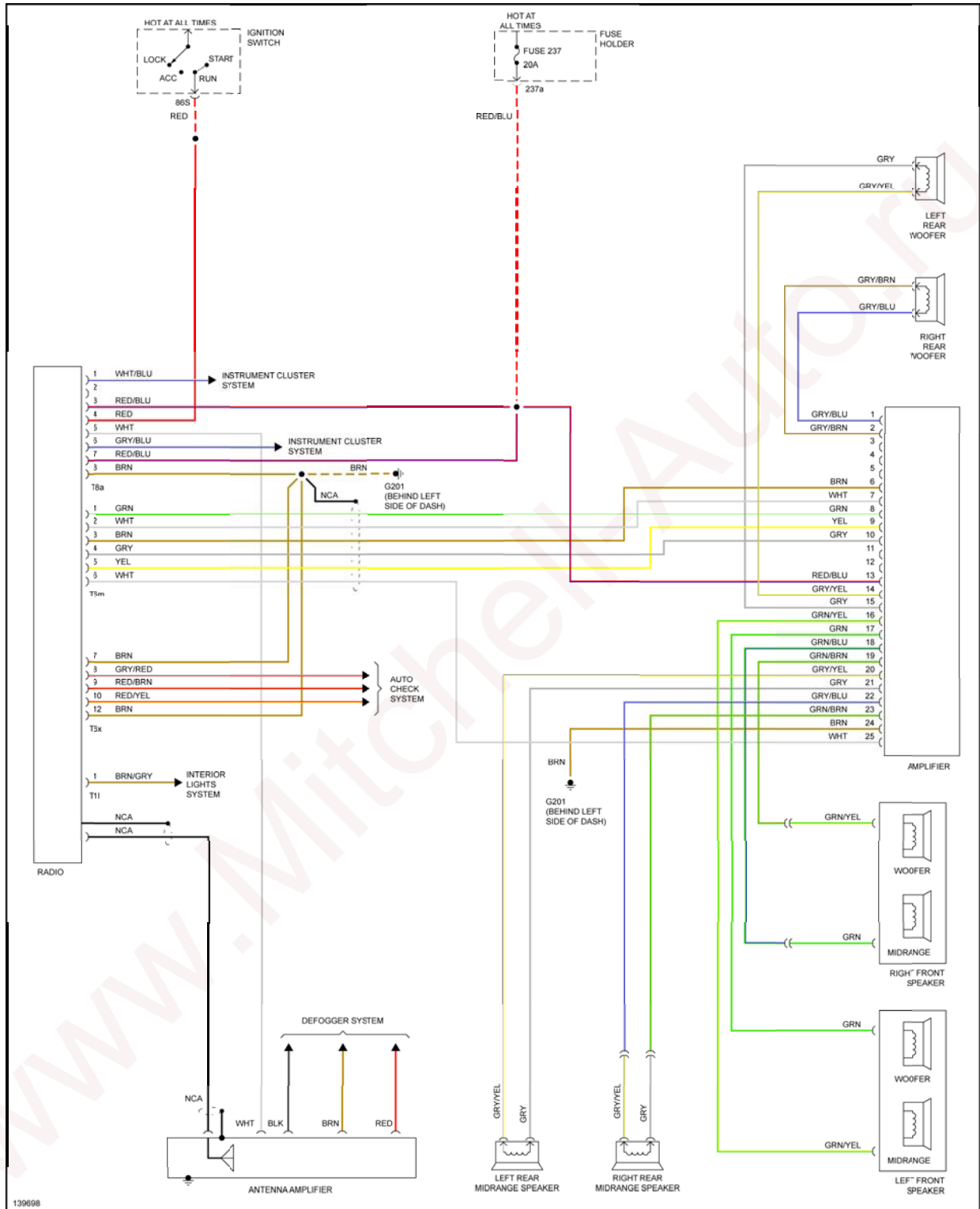

Fig. 32: Radio Circuit

## SHIFT INTERLOCK

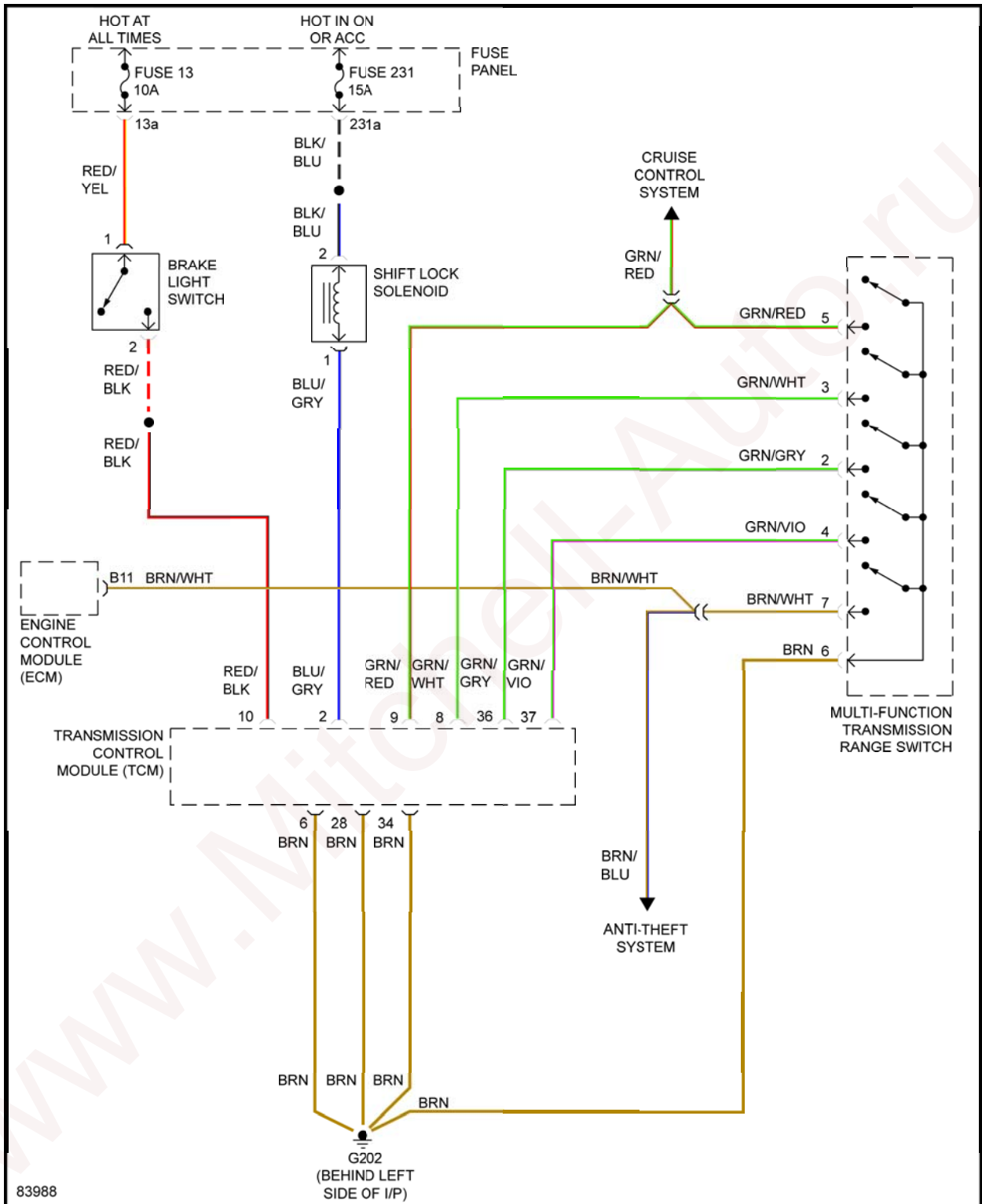
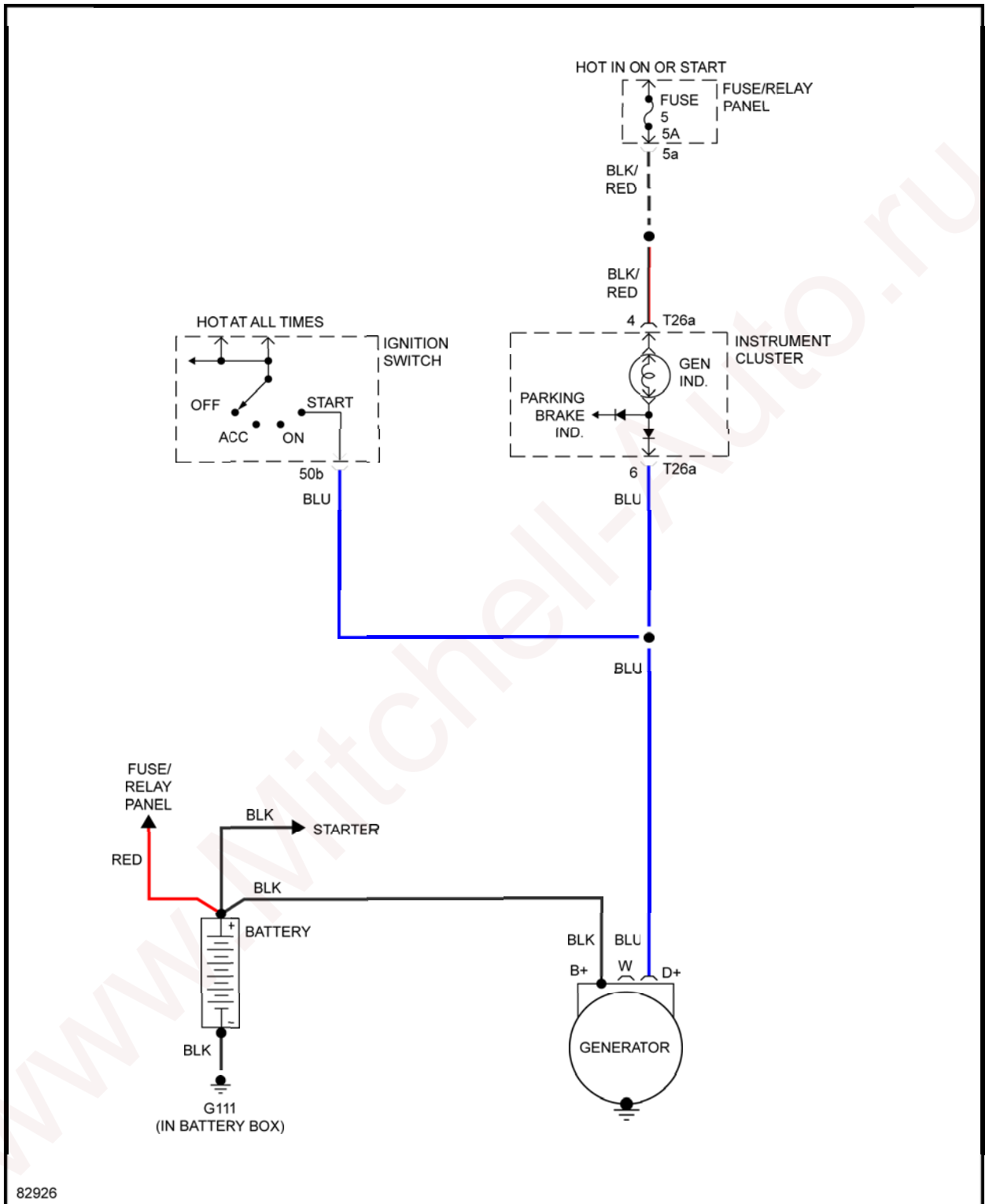

Fig. 33: Shift Interlock Circuit

## STARTING/CHARGING



82926

Fig. 34: Charging Circuit

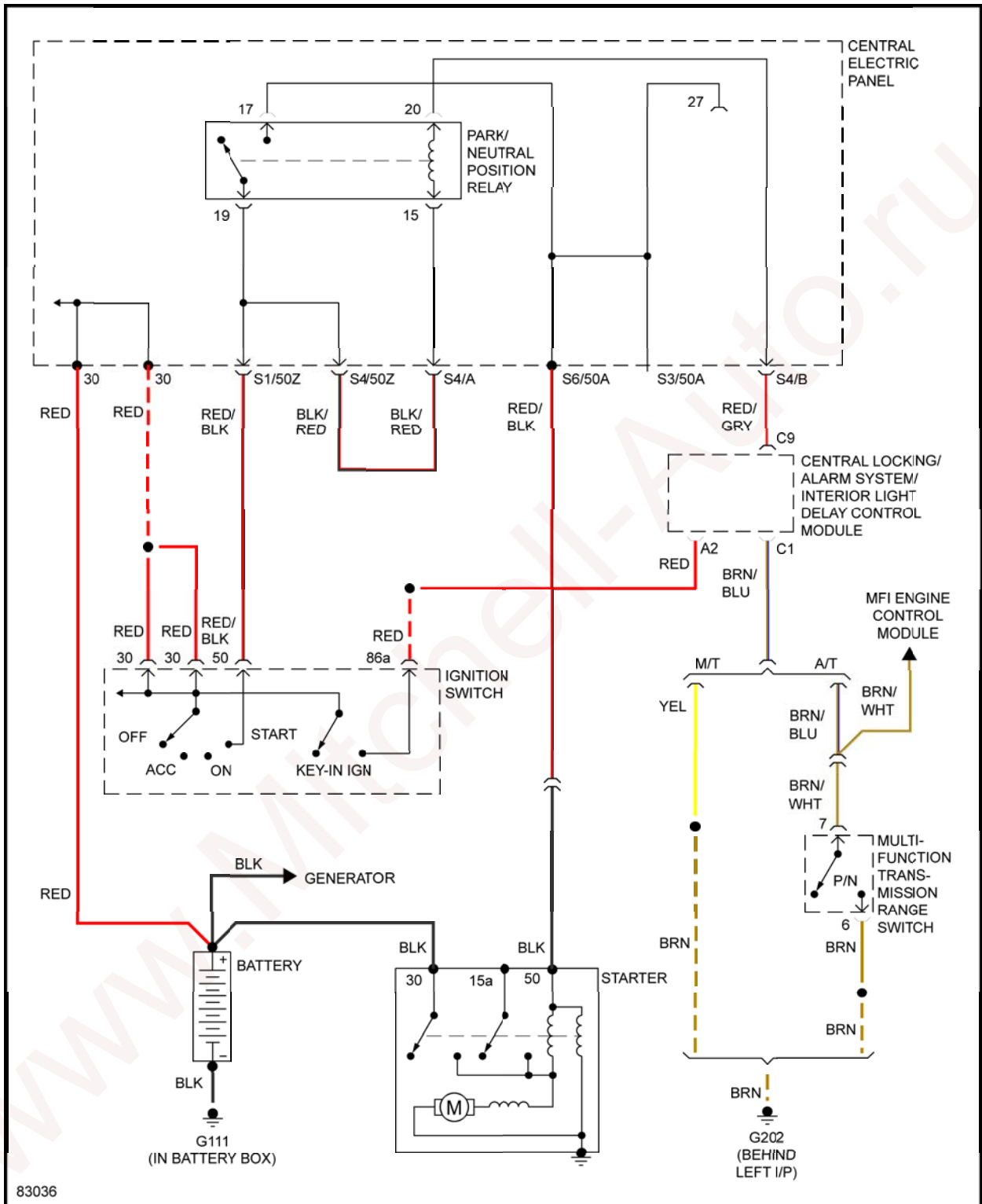

Fig. 35: Starting Circuit

**SUPPLEMENTAL RESTRAINTS**



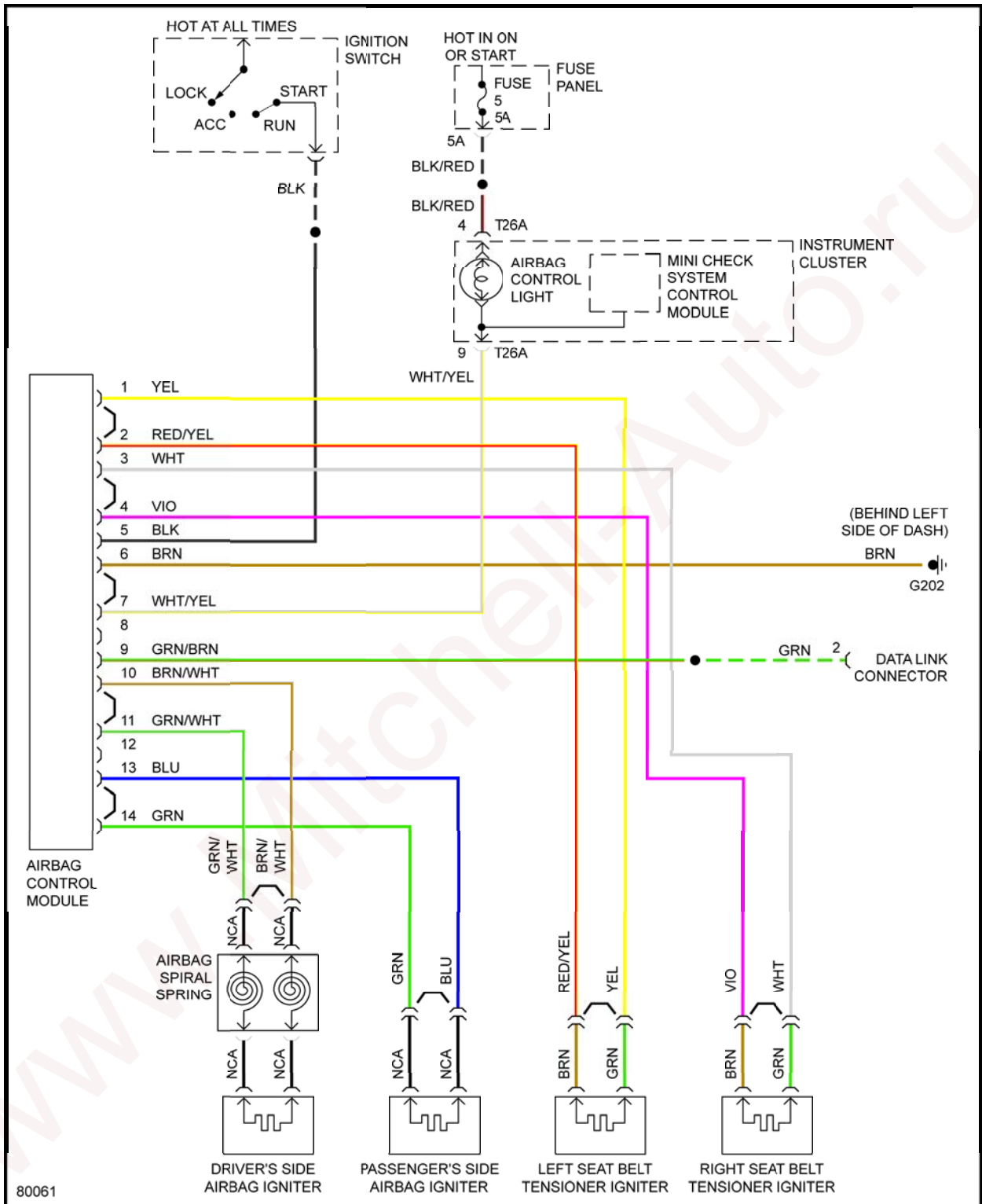

Fig. 36: Supplemental Restraints Circuit

## TRANSMISSION

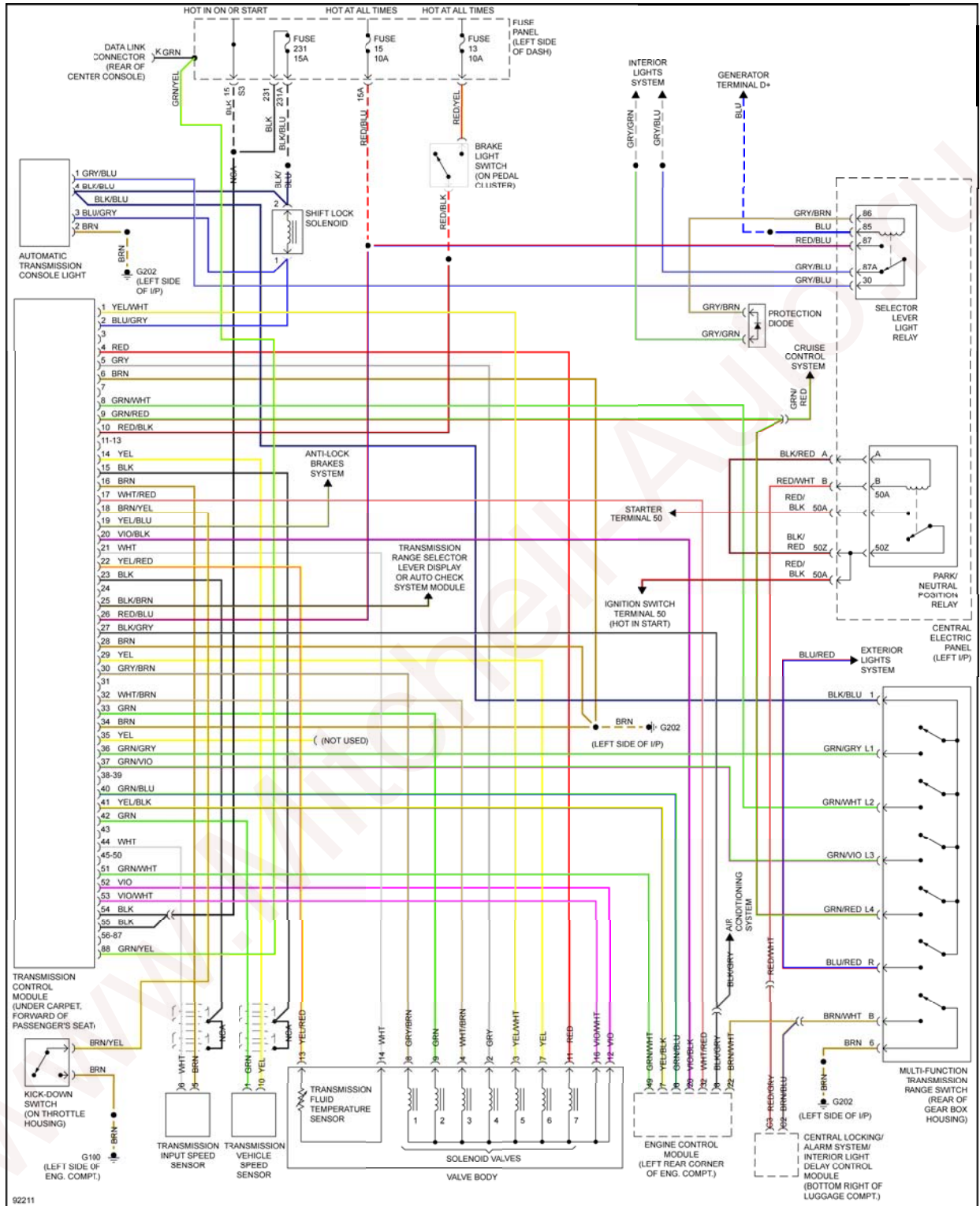

Fig. 37: A/T Circuit

## WARNING SYSTEMS

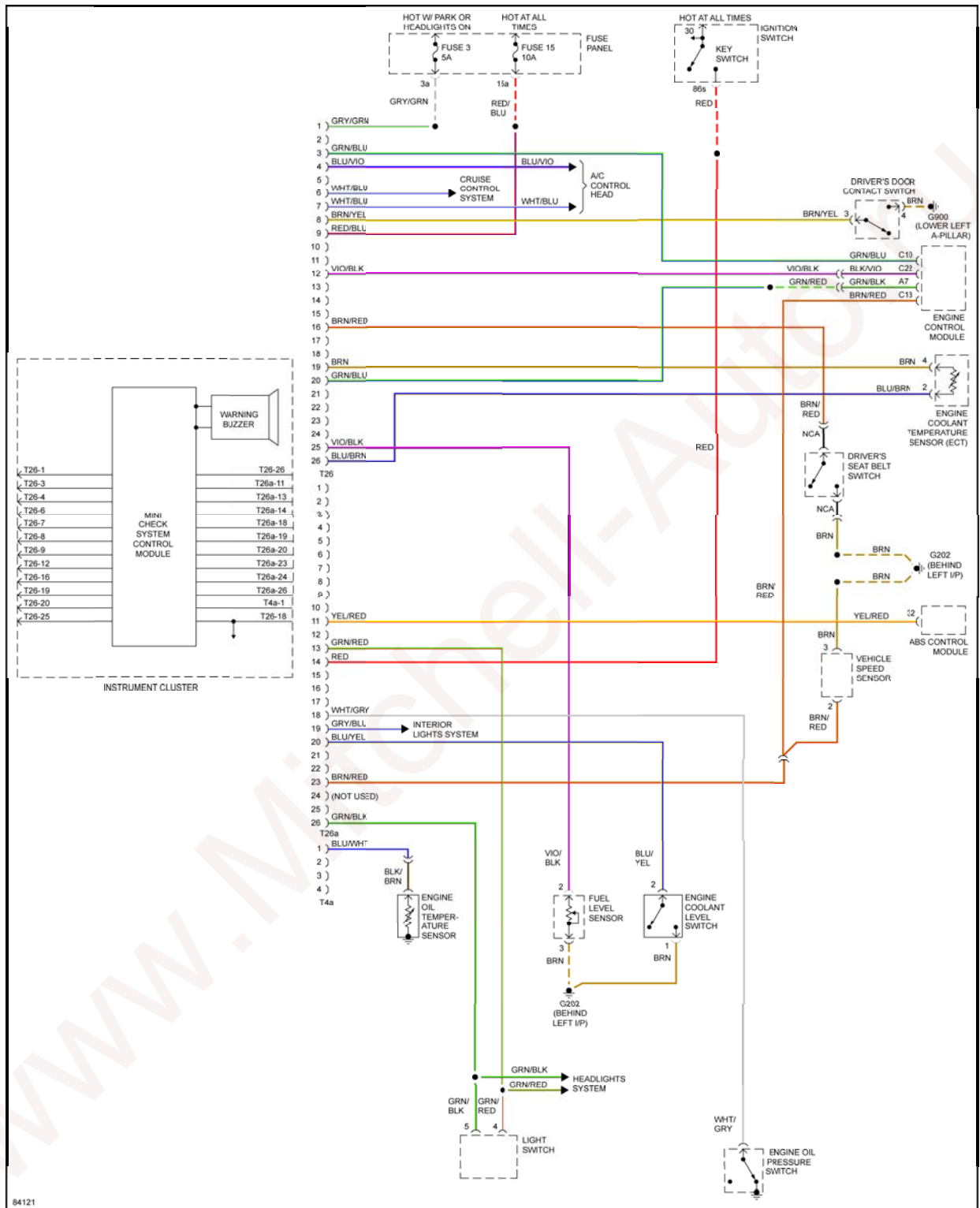

Fig. 38: Warning Systems Circuit

## WIPER/WASHER

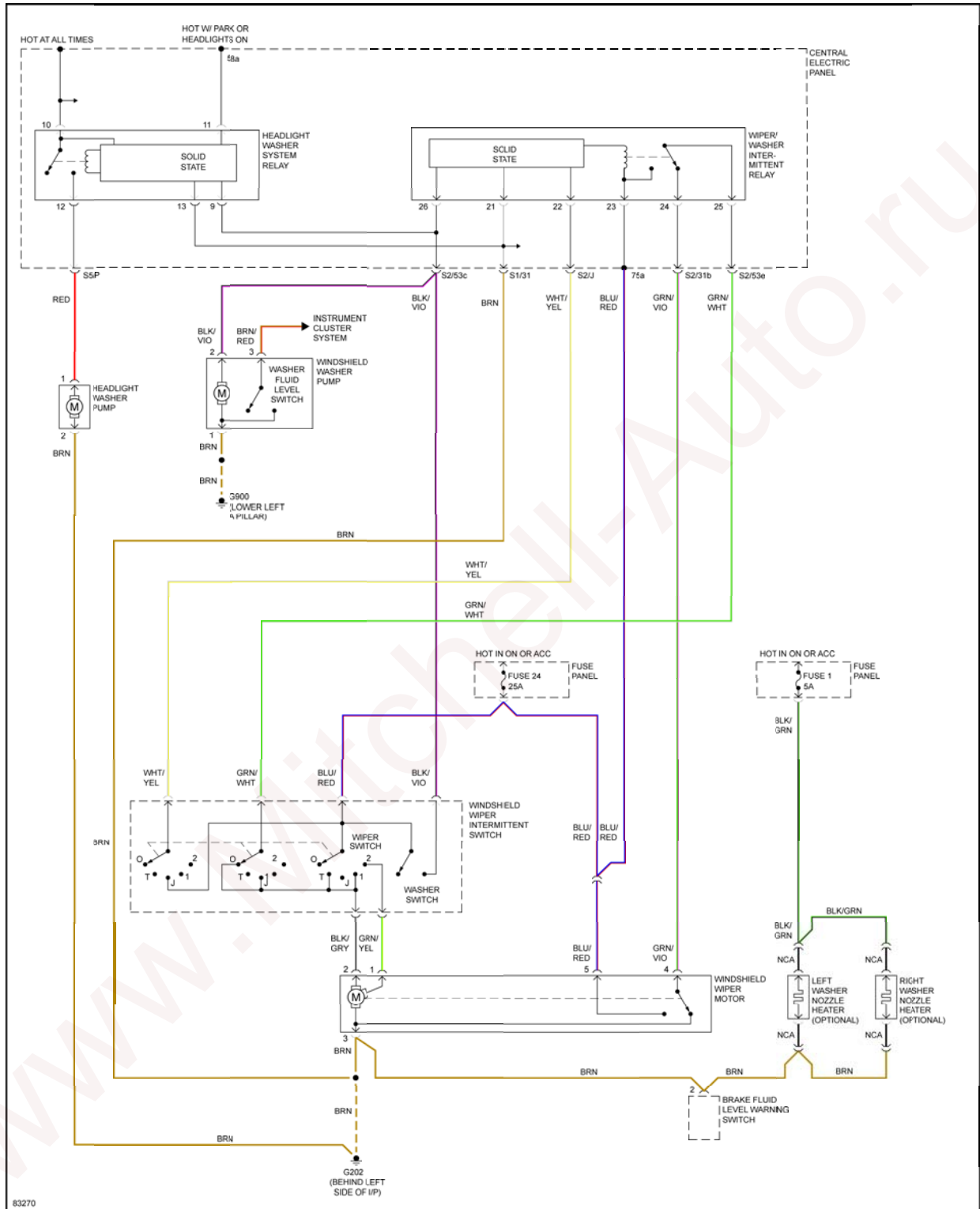

Fig. 39: Wiper/Washer Circuit